

**User Manual &
Spare Parts Catalogue**

(EN) 10-11-2021

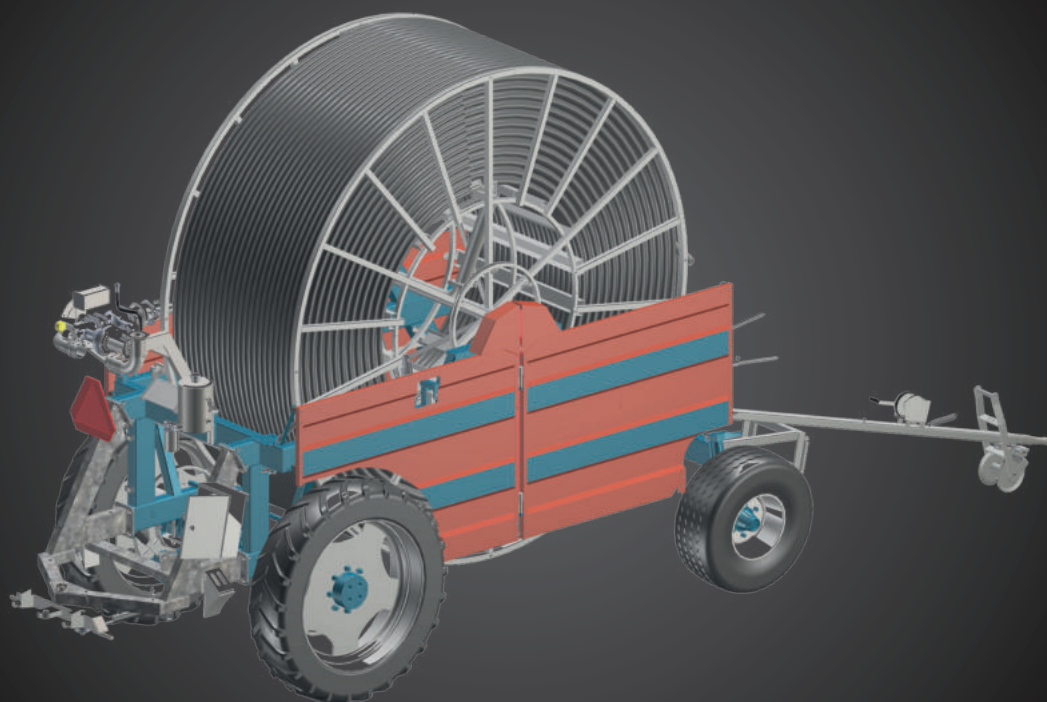

Irrigator FM4550



Fasterholt Maskinfabrik A/S
Ejstrupvej 22
7330 Brande
Danmark

Telephone: +45 97 18 80 66
Telefax: +45 97 18 80 40
E-mail: mail@fasterholt.dk
Web: www.fasterholt.dk

<u>Declaration of Conformity</u>	<u>3</u>
<u>General safety</u>	<u>4</u>
Operating instructions for Fasterholt FM 4550	4
<u>Product labelling</u>	<u>5</u>
Symbols	5
<u>Operating instructions</u>	<u>7</u>
Starting your irrigator	7
Preparing the machine for irrigation	7
Preparing the machine after irrigation	8
Maintenance	8
Preparation for winter	8
Faults on the Irrigator	9
Setting the gun	9
<u>Technical data</u>	<u>10</u>
Nelson SR 150	11
<u>Spare parts</u>	<u>32</u>
Front axle and drawbar	32
Front axle	34
Cross track shaft	36
Shields	38
Turbine for drum	40
Parts on frames	44
Drum	48
Stop bar	50
Hydraulics	52
Flat gear	54
Rear drawbar	56
Turbine installation	60
Turbine	62
Rear axle assembly	70
Rear axle assembly parts	74
Sensor	76
Gun	78
<u>Optional equipment</u>	<u>83</u>

EEC Declaration of conformity

Manufacture (name and address):

Fasterholt Maskinfabrik A/S

Adresse: Ejstrupvej 22,
Fasterholt
Ort: 7330 Brande
Country: Denmark
Web: www.fasterholt.dk

CVR: 58 83 28 12
TEL: +45 97 18 80 66
FAX: +45 97 18 80 40
E-Mail: mail@fasterholt.dk

Hereby is certified that the following product:

Description, ID/mark, type:

Irrigator FM 4550

Serial No. if any:

Notified body if any:

EEC-type certificate if any:

EN 908:1999+A1:2009.
DS/EN/ISO 12100:2011.
DS/EN/ISO 14120:2015.

Harmonised standards if any:

Is made according to the announcement no.693 of 10. Jun 2013 that implements the DIRECTIV 2006/42/EC.

Name, title and signature of manufacture:

Date

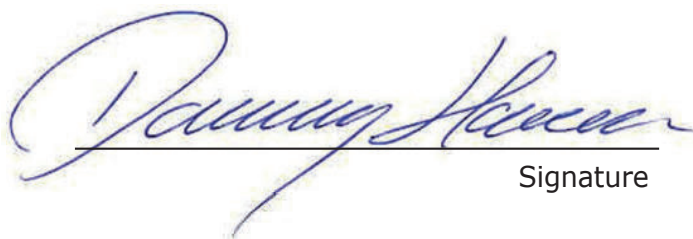

Signature

!!! Important !!!

READ THIS MANUAL BEFORE USING YOUR IRRIGATOR !!

Operating instructions for Fasterholt FM 4550

Your new Fasterholt Irrigator is a Danish built machine, but even the best machines only deliver top results when they are properly used and maintained.

To ensure that the machine complies with the EU Machinery Directive, only original spare parts may be used. Otherwise, compliance will be lost and safety will be entirely at your own risk.

The irrigator is intended for irrigation with clean water from a drilled well or a watercourse.

1. Safety instructions/warnings !!

- It is forbidden to stand on the machine during irrigation and transport **(risk of fatal injury)**.
- The guards are fitted for your own safety - please leave them in place
- Remember to tighten the wheel bolts
- When starting the machine on falling ground, you must be **VERY** careful not to disconnect the tractor from the machine until the machine has been put into gear, otherwise the machine may run away.
- If a rear wheel is removed, **THE MACHINE MUST BE JACKED UP AND VERY STABLE**, because if it overturns, it will fall completely on its side.

WARNING !!

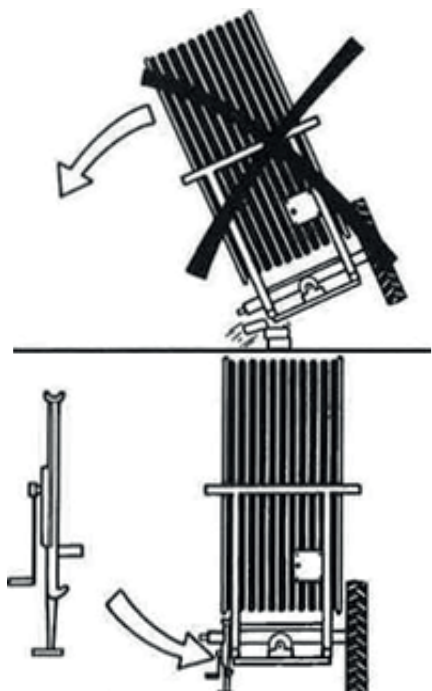

- To perform an EMERGENCY STOP, pull the cable for the miswinding bar or press STOP on the COMPUTER
- V-belts may only be fitted after the machine has been unwound for the first time. (only the first time the machine is used for irrigation.)
- The gun must face out to the side when unwinding the machine.
- **STAND ASIDE** when the gun is operating.
- **WARNING** against contact with overhead power lines with the machine or water jet. Avoid irrigation on or near power lines.
- During transport on uneven roads/fields, move **VERY** carefully according to the conditions.
- Max. transport speed with water in the hose is 15 km/h.
- When parking the machine, use the wheel chocks mounted by the rear wheels
- **DANGER !!** Avoid welding in the paint layer! Before welding, remove all paint from the welding area
- Avoid inhalation of grinding dust.
- Hydraulic oil can be harmful to health:
- Skin contact may cause allergies
- Inhalation of oil mist may cause lung disease
- Leakage of oil under high pressure is dangerous, an oil jet can enter the skin, eyes, etc.
- If a hydraulic system leak is found, stop the system immediately and rectify the fault.
- Note that due to operation, the oil may be 70 degrees Celsius or even hotter. This can lead to a risk of scalding during separation.
- **IMPORTANT** Maximum battery charging power is 2 amps. Charging more than 2 amps may cause the battery to crack. The battery must be charged at a temperature between 0 °C and +40 °C. NEVER place the battery in a sealed container while charging. During winter, the battery must be removed and stored in a dry place indoors in a fully charged state.
- Avoid sparks and flames on and around the battery.
- Do not short circuit the battery.
- Never disassemble the battery.
- If you come into contact with the battery's sulphuric acid, wash immediately with water. If acid comes into contact with eyes, rinse thoroughly with water and seek medical attention immediately.
- Pay attention to the battery compartment. If there are cracks, deformities, electrolyte leakage, etc., replace the battery immediately.
- If the battery is dirty, clean it as soon as possible.
- Disposal of oil spills:
- If oil spills are found, they should be cleaned up immediately with rags or oil absorbent powder.
- Spilled products, as well as rags and powder used for oil spills, must be stored in sealed metal containers and delivered to the municipal collection site.
- Batteries, hoses, tyres and other parts of the irrigation machine must be disposed of at an approved recycling site.

If the machine is to be moved via a public road, the machine must first be emptied of water.

Symbols

The following symbols are used in this product and the following documentation.



WARNING Indicates a potentially hazardous situation. Failure to avoid the situation may result in death or serious injury.

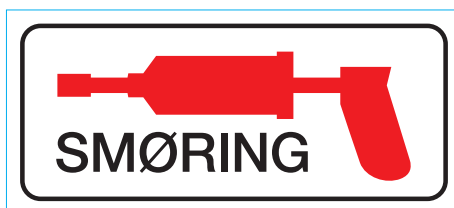

LUBRICATION Indicates lubrication is required as per the service description



SERVICE WARNING Indicates a service hazard

Starting your irrigator

Move the machine to the field in the transport position. When the machine is at the crop to be irrigated, disconnect the tractor from the front drawbar. Connect the tractor to the rear drawbar. **Recommendation: Remove the drum belt from the belt tensioner before unwinding. When the machine is at the target, reattach the belt to the belt tensioner before disconnecting the machine.** Insert the electric brake connector in the female connector for the tractor lights. The machine then winds up in the crop and stops. **Disengage the pawl.**

REMEMBER !! When starting the machine on falling ground, you must be VERY careful not to disconnect the tractor from the machine until the machine has been put into gear, otherwise the machine may run away.

Attach the charge hose to the hydrant, if necessary turn on the hydrant.



During irrigation

Safety stop

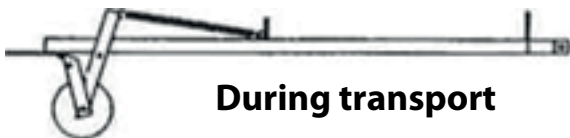

During transport



Stop pawl

Secure the hose chains with the long ground spikes. Lower the drawbar over the hose and release the safety stop so the hose reel runs on the hose .

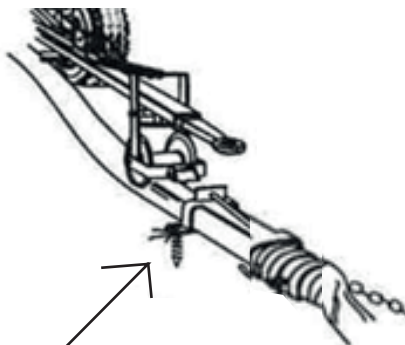

Ground spike

Unwind the machine with the brake applied sufficiently to keep the hose tight at all times with the electric brake.

If you do not lay the hose straight out, be **very careful** to ensure that the hose is always tightened on the hose drum.

The machine should be unwound completely at least every 3rd time.

Before starting to unwind the machine, reset the COMPUTER. To do this, press the TOGGLE SWITCH located on the side of the electric box upwards (reset) .

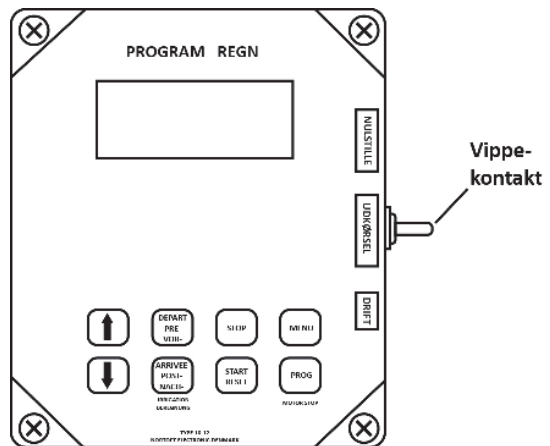

When unwinding the machine, the TOGGLE SWITCH must be in the centre (unwind) so it cannot reset on the way out. After unwinding, press the TOGGLE SWITCH down (operation).

Winding speed: Recommended max. 5 km/h

Preparing the machine for irrigation

ALWAYS REMEMBER that the TOGGLE SWITCH must be pressed down during operation, otherwise the machine will not move. Engage the pawl.

Tighten the V-belt (belt tension lever) so the spring is fully compressed around the spacer pipe

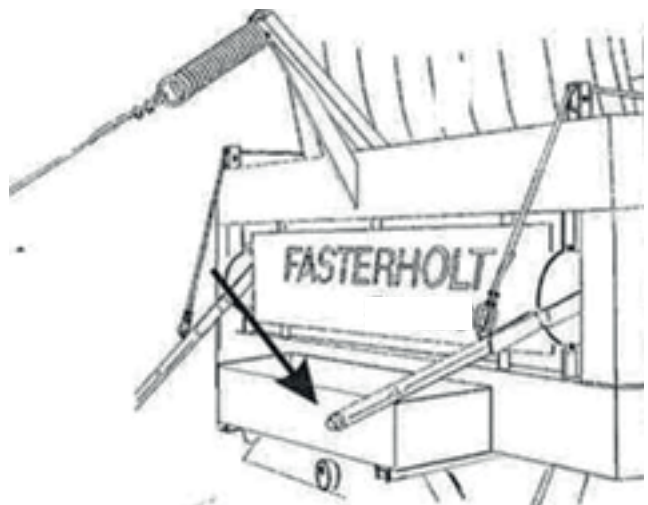

Release the brake lever completely. (Optional equipment. Remember also to release the electric brake) (Remember that the electric brake connector must be removed from the tractor)

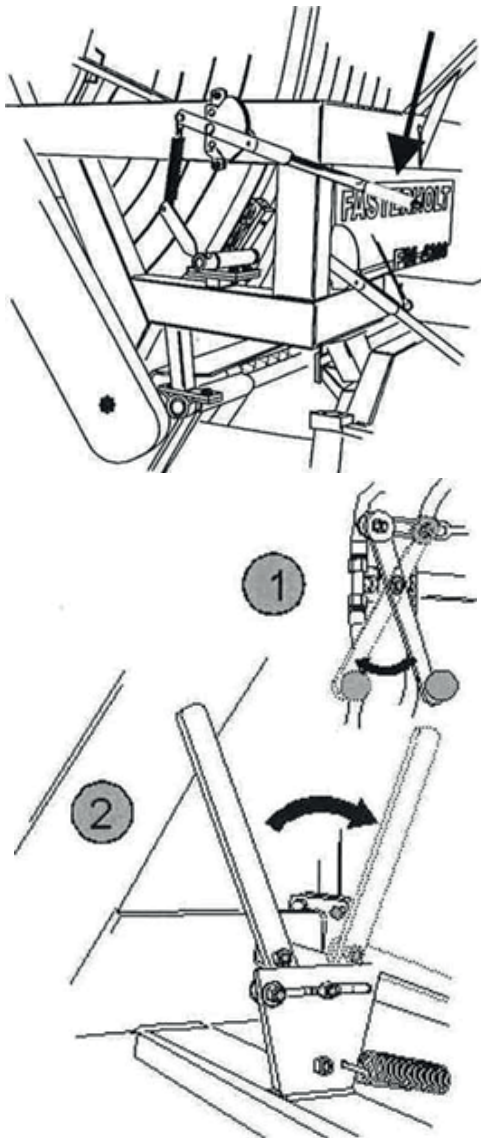

Before connecting the tractor to the rear of the machine, disengage the gear and raise the drawbar at the front before starting the machine.

Remember to close the decoupling valve (**lever "1" must be pulled out.**)

REMEMBER to connect machines with coupling levers (**lever "2" pushed in**)

Attach the charge hose to the hydrant. Then open the hydrant, start the pump and irrigation can begin. The speed you want to move at is set in Program Rain. You do not have to select a gear as this is stepless speed regulation controlled by Program Rain. On some other models, gears are selected according to the machine instructions.

When starting irrigation, see the section that refers to the operating instructions for PROGRAM RAIN.

Preparing the machine after irrigation

After irrigation, tighten the brake and loosen the V-belt. Then open the bypass valve (lever "1" must be pushed in) to get the gearbox out of gear (lever "2" pulled out). If there is tension in the rear axle assembly, use a fork wrench to turn the input shaft to release the coupling.

ALWAYS REMEMBER THAT THE COUPLING MUST BE RELEASED (COUPLING LEVER PULLED BACK) WHEN THE MACHINE IS NOT MOVING BY ITSELF.

Maintenance

1x per week:

Check that no water is entering the oil on the rear axle assembly.

Lubricate the steering, roller chain for hose guides, roller chain for forward traction, cross track shaft for hose guide with water-repellent grease.

Check tyre pressure:

Rear wheels 2.4 bar/ 34.8 psi

Front wheels 2.4 bar/ 34.8 psi

Check that front and rear drawbars line up. If not, turn the lever on the side of the machine by the front control cylinder. This is how to adjust the drawbars so they line up. Turn the lever back again.

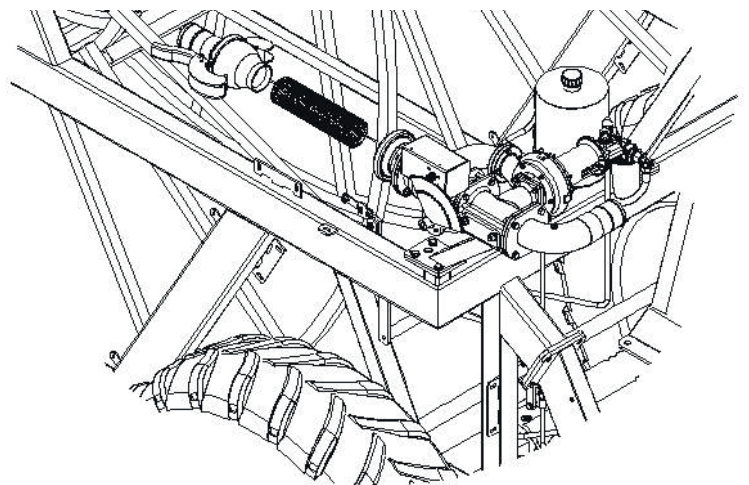

Clean the filter at the turbine outlet if required. Check that the hose is positioned neatly.

Remember to check the guide pins in the hose guides regularly

Remember to tighten the wheel bolts regularly.

NOTE:

The battery should be charged once a month during the season to maintain full power and extend its useful life.

Preparation for winter

Drain water from the machine:

The machine is easily emptied with air (only done with special compressors).

Contact Fasterholt Maskinfabrik A/S if necessary.

REMEMBER !! Before unwinding the hose:

Open the filter coupling.
Open the valve in the base of the turbine.

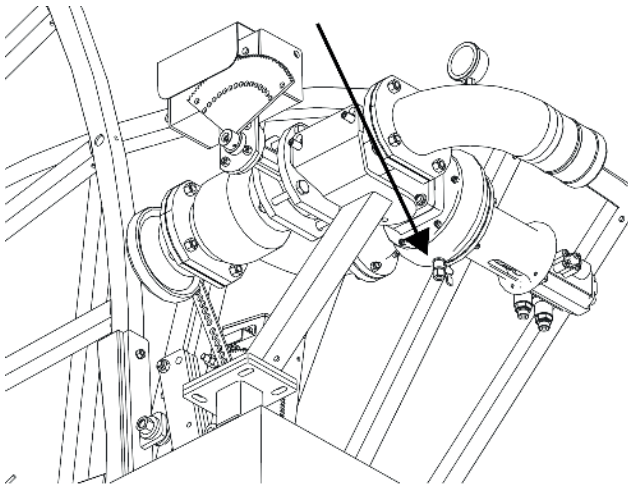

On machines with high pressure stops, press START to open the main valve and allow the water to flow out freely. (Disconnect battery lead so stop valve does not close again.) Press stop motor on Prog. key

Remove the battery and do not install it until the next time you use the machine.

Lubrication of:

Front wheel hubs, front spindle, hose guides, bearings on hose guides, wheels.

Check for water in the oil in the rear axle assembly and hydraulic tank.

Oil in the rear axle assembly/gears should be changed every 1,000 hours. Hydraulic oil and filter should also be replaced every two years.

Lubricate the steering, roller chain for hose guides, roller chain for forward traction, cross track shaft for hose guide with water-repellent grease.

Check tyre pressure
(see page 9)

Guide pins should be replaced every year.

Faults on the Irrigator

Check the following before calling a technician:

1. If the machine is irrigating, but not moving.
 - a. Check that machine is in gear.
 - b. Check if it is performing pre-irrigation or post-irrigation. (can be seen on the display under menu 3.)
 - c. Check if pressure drop valve is closed.
 - d. Check that end stop sensor is in place. (can be seen on the display under menu 3.)
 - e. Check that toggle switch is in operation position.
 - f. Check that decoupling valve is closed (for hydraulic motor)
 - g. Check that filter at turbine outlet is not blocked.
 - h. Check that turbine can turn easily.
2. If the machine does not wind up the hose properly, it may be that:
 - a. The hose guide needs to be adjusted:
To adjust the guide, remove the chain from the hose guide to the cross track shaft. Then turn the cross track shaft until the hose guide fits the hose again.
 - b. The guide pin is worn and needs to be replaced.
 - c. The V-belts are too slack or excessively worn: To tighten the belt, move the hole plate at the end of the cable. If it cannot be moved any further, the cable needs to be shortened.
3. Forced steering is not lined up and seems springy.
 - a. There is a leak at the coupling or assemblies, so the oil has drained out, leaving air in the system.
 - b. The system must be vented (call a technician).

Setting the gun

The operating pressure of the gun should be 4.5 - 5.0 bar depending on the type of gun and the water volume. For high water volumes, the pressure should be higher.

The best spreading width is achieved at a sector angle of approx. 200 degrees. This means that the gun operates over an angle of 200 degrees.

Technical data

8. Data for FM 4550

Hose PEMD 100 mm
Capacity up to 55m³ - hose length from 500 to 675 m.

Hose PEMD 110 mm:
Capacity up to 75 m³ - hose length from 350 to 550 m.

Wheel size:

Rear wheels: 12.4"x36" x 10 ply - air pressure 2.4 bar / 34.8 psi

Front wheels: 13.0"/75x16" x 10 ply - air pressure 2.4 bar / 34.8 psi

Speed at 35 m³ and above:

15-30 metres per hour

Weight of FM 4550

Weight without water with 550 m/110 mm hose: 4164 kg.

Weight with water with 550 m/110 mm hose: 7210 kg.

Track width (Standard): 1810 mm.
Can be ordered with: 2010 mm.

Gun: Nelson SR 150

Oil in rear axle assembly.....: 16 litres 80/ 90 gear oil
Track width 1810 mm.

Oil in rear axle assembly.....: 18 litres 80/ 90 gear oil
Track width 2010 mm.

Oil in flat gear...: 1.5 litres 80/ 90 gear oil

Hydraulic oil.....: 10 litres STATOIL Hvxa 46

Grease for lubrication: FUCHS Greaseway CAH 92 or equivalent.

Width 210 cm.
Length without drawbar 575 cm.
Height 363 cm.

Optional equipment:

Rear axle assembly with track width 2010 mm.

Nelson SR 150

Factory-adjusted to Danish conditions and ready to use after the following three steps:

1. Select the nozzle size that best suits your application and install it. Performance data for the different sizes are shown in the table below.
2. Adjust the stop on the part circle to obtain the desired irrigation angle.
3. There is a grease fitting which should be checked once a week for refilling.

ADJUSTMENT

The only thing you can adjust is the counterweight on the drive arm. By moving the counterweight forward, the gun will slowly irrigate from side to side. If you move the counterweight back, the gun will irrigate quickly. If it does not irrigate quickly enough, you can remove the brake springs (no. 778474) in pairs (contact the service department)

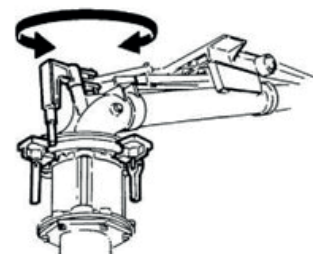

WARNING: DO NOT ADJUST WHEN THE GUN IS IRRIGATING !! DANGER.....: HIGH WATER PRESSURE – STAY CLEAR !!

Dysetabel for Nelson SR150 kanon, 21°- Plastdyser.

Tryk (Bar)	18mm		19mm		20mm		21mm		22mm		23mm		24mm	
	m ³ /h	Rad.(m)	m ³ /h	Rad.(m)	m ³ /h	Rad.(m)	m ³ /h	Rad.(m)	m ³ /h	Rad.(m)	m ³ /h	Rad.(m)	m ³ /h	Rad.(m)
3,5	20,2	32,5	22,7	33,5	25,4	34,5	28,0	36,0	30,9	36,5	34,1	37,5	37,5	38,8
4,0	21,6	33,5	24,3	34,5	27,1	35,7	29,9	36,5	33,0	37,8	36,4	38,8	40,1	40,0
4,5	22,9	34,5	25,7	35,7	28,7	36,5	31,7	37,8	35,0	39,2	38,6	40,5	42,5	41,4
5,0	24,2	35,2	27,1	36,5	30,3	37,8	33,4	39,2	36,9	40,5	40,7	41,4	44,8	42,7
5,5	25,3	36,5	28,5	37,8	31,7	38,7	35,1	40,0	38,7	41,4	42,6	42,7	47,0	44,0
6,0	26,5	37,4	29,8	38,7	33,1	40,0	36,6	41,4	40,4	42,7	44,5	44,0	49,0	45,3

Tryk (Bar)	25mm		26mm		27mm		28mm		29mm		30mm		31mm	
	m ³ /h	Rad.(m)	m ³ /h	Rad.(m)	m ³ /h	Rad.(m)	m ³ /h	Rad.(m)	m ³ /h	Rad.(m)	m ³ /h	Rad.(m)	m ³ /h	Rad.(m)
3,5	41,0	39,6	44,8	40,5	49,0	41,8	53,3	42,7	57,9	44,0	62,8	44,8	67,8	45,8
4,0	43,8	40,9	47,8	42,2	52,3	43,1	57,0	44,5	61,9	45,8	67,1	46,6	72,5	47,5
4,5	46,5	42,7	50,7	43,6	55,5	44,5	60,5	45,8	65,7	47,0	71,2	48,0	76,9	49,3
5,0	49,0	44,0	53,5	44,5	58,5	46,2	63,8	47,5	69,2	48,4	75,1	49,7	81,1	50,6
5,5	51,4	44,5	56,1	46,2	61,4	47,5	66,9	48,8	72,6	50,2	78,7	51,0	85,0	52,4
6,0	53,7	46,2	58,6	47,5	64,1	48,8	69,9	49,7	75,8	51,0	82,2	52,4	88,8	53,7

Tryk (Bar)	32mm		33mm		34mm	
	m ³ /h	Rad.(m)	m ³ /h	Rad.(m)	m ³ /h	Rad.(m)
3,5	73,1	46,6	78,7	47,5	84,5	48,4
4,0	78,1	48,4	84,2	49,3	90,3	50,2
4,5	82,9	50,2	89,3	51,0	95,8	51,9
5,0	87,4	51,9	94,1	52,8	101,0	53,2
5,5	91,6	53,2	97,8	54,1	105,9	55,0
6,0	95,7	54,6	103,0	55,4	110,6	56,3





Functions:

- Speed regulator
- Pre- and Post-irrigation
- 4 different speeds on sections of the lane
- Clock
- Setting the start time
- Stop time is shown on the display
- Length of hose
- Current speed
- Battery volts
- Charge regulator

Pressure sensor

- Stop sensor
- Speed sensor
- Motor 1, regulating motor
- Motor 2, stop motor
- Slow start of turbine
- Slow closing of inlet
- Water volume + spreading width
- Accessories:
- GSM, SMS messages for remote control.
- Analogue pressure sensor.

Short instructions for use



Place machine:

SPEED	30.0m/h
DOSE	22 mm
TIME	7:28 STOP 7:28
STATUS	STOP Sensor

Move machine to a new lane. Display shows start and stop time. Pull hose out to end of the lane. (ex 250 m)

Select Speed:

SPEED	30.0m/h
DOSE	22 mm
TIME	7:56 STOP17:16
STATUS	STOP Sensor

Display now shows stop after 9h 20m. Press the "+" or "-" key to set the speed. Speed can be adjusted during irrigation.

SPEED	25.0m/h
DOSE	26 mm
TIME	7:58 STOP17:58
STATUS	STOP Sensor

SPEED has decreased, DOSE has increased and STOP time is later.

Start Irrigate, Select PRE- and POST Irrigation.

SPEED	25.0m/h
DOSE	26 mm
TIME	7:58 STOP17:58
STATUS	STOP Sensor

Press START to start. Press PRE and POST for pre- and post-irrigation respectively. STOP time will be later when PRE and POST irrigation are selected.

Starting:

SPEED	25.0m/h
DOSE	26 mm
TIME	8:00 STOP18:38
STATUS	Running

The turbine will start when the water pressure increases. After a short period, the regulator finds the correct speed. Irrigation continues until STOP SENSOR is activated at the end of the lane.

-PRE Irrigation

SPEED	25.0m/h
DOSE	26 mm
TIME	8:02 STOP18:38
STATUS	PRE Irrigate

If pre-irrigation is selected, the turbine stops immediately after performing a start and pre-irrigation. When the pre-irrigation time has elapsed, the turbine starts and the machine changes status to Irrigating.

-POST Irrigation

SPEED	25.0m/h
DOSE	26 mm
TIME	18:20 STOP18:38
STATUS	POST Irri.

If post-irrigation is selected, the turbine stops at the end of the lane when the stop sensor is activated. Post-irrigation then starts.

Stop:

SPEED	25.0m/h
DOSE	26 mm
TIME	18:38 STOP18:38
STATUS	STOP Sensor

Stop sensor is activated, turbine and water are shut off. The machine is now ready to be moved to a new lane.

General instructions for use

MENU's

```
SPEED      30.0m/h
DOSE       22 mm
TIME 14:10 STOP 7:43
STATUS Running
```

Standard display

```
ZONE      1 30.0m/h
DOSE      22 mm
TIME 14:10 STOP 7:43
STATUS Running
```

Standard display, ZONE irrigation is selected.

```
DISTANCE   123m
BATTERY    12.8V
CHARGE ON  0.231A
PRE. 0:45 POST 0:45
```

Press the **MENU** key 1 time to display menu 2

```
PRESS SENSOR
STOP SENSOR
SPEED SENSOR
MOT1 0.0A MOT2 1.8A
```

Press the **MENU** key 2 times to display menu 3

```
ACTUAL SPEED 22m/h
START        0:00
STOP        7:45
WORKING HOURS 123h
```

Press the **MENU** key 3 times to display menu 4

```
0m 30.0m/h 0m
0m 30.0m/h 0m
0m 30.0m/h 0m
0m 30.0m/h 0m
```

Press the **MENU** key 4 times to display menu 5

```
SIGNAL 23
NETWORK HOME
A: +45123456
B: +45234567
```

Press the **MENU** key 5 times to display menu 6
(Only if GSM is selected)

When characters **■** appear in the display, this indicates that the relevant function is ON

Standard menu:

SPEED	30.0m/h
DOSE	22 mm
TIME 14:10 STOP 7:43	
STATUS Running	

Standard display

- SPEED** Speed. Can be changed at any time during irrigation using the "+" and "-" keys.
- ZONE** Current zone 1...4, with corresponding speed. The speed cannot be changed. (Zone active)
- DOSE** The dose is calculated from the speed and constants and shows the current number of mm for irrigation. As SPEED increases, DOSE decreases. (Constants 11 and 12)
- TIME** To set the time: Set SPEED to 11.1 m/h and press the **PROG** key 3 + 1 times until the display shows <CONST 1 TIME>. The time can then be set with the "+" and "-" keys. When the battery has been disconnected, the clock will show 0:00 until it is set again.
- STOP** The time that irrigation is completed, incl. pre- and post-irrigation. If the clock is not set and shows 0:00, the total irrigation time is displayed.
- STATUS** Irrigation status, e.g.:
- | | | |
|---|-----------------|---|
| < | Stop sensor | > |
| < | Irrigating | > |
| < | Pre-irrigating | > |
| < | Post-irrigating | > |
| < | LOW pressure | > |
- See explanation in STATUS chapter.

If the display shows: **LOW BATTERY** instead of SPEED, the battery voltage is below 11.8 V and the battery needs to be charged.

MENU 2

DISTANCE	123m
BATTERY	12.8V
CHARGE ON	0.231A
PRE. 0:45 POST 0:45	

- DISTANCE Length of the unwound hose. The length can be changed immediately after pressing the **PROG** key 3 times, using the "+" and "-" keys.
- BATTERY Battery voltage.
- CHARGER ON Shows when the battery is being charged by a solar cell. The battery is charged when the voltage is below 14.0 volts.
- PRE Shows the pre-irrigation time.
- POST Shows the post-irrigation time.
- The pre- and post-irrigation times can be changed immediately after pressing the **PRE-** or **POST-** keys, using the "+" and "-" keys.

MENU 3

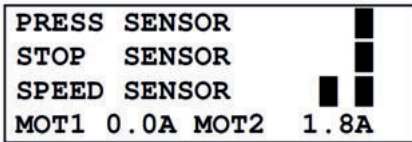

PRESSURE SENSOR

Shows that the pressure is high when block is lit. **The machine can only move when the pressure is high.** If no pressure sensor is fitted (machine data 14 = 0), the machine will operate regardless of pressure status.

The machine can be fitted with analogue pressure sensors. Sensors must be connected according to the diagram. Pressure sensor functions, except for pressure display, are the same as for digital pressure sensors. There are constants for the pressure sensor type. Similarly, set point and hysteresis can be selected for each machine.

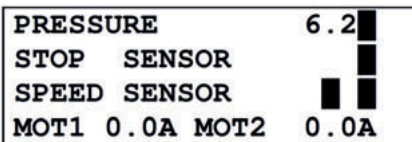

Shows pressure in [BAR] (00.0) or [PSI] (000). Pressure is high when ■ is lit.

The machine can only move when the pressure is high.

If no pressure sensor is fitted (machine data 14 = 0), the machine will operate regardless of pressure status.

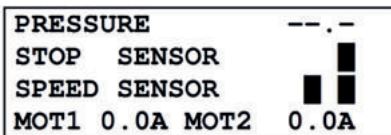

STOP SENSOR

Shows that the magnet is aligned with the stop sensor when block is lit.

The machine can only start when the magnet is aligned with the stop sensor.

The stop sensor has 3 functions:

1. Reset distance.
2. Post-irrigation.
3. Stop pulses to the regulator motor.

SPEED SENSOR

For the speed sensor test, block is only lit when the magnet passes the sensor.

MOT1, MOT2

Displays the current motor current. When the current exceeds 4.5 A, the motor stops.

If the current exceeds 4.5 A and the valve is not in the outer position, there may be a blockage in the valve.

MENU 4

ACTUAL SPEED	22m/h
START	0 : 00
STOP	7 : 43
WORKING HOURS	123h

- CURR. SPEED** Shows the current speed. That is, the speed at which the machine is moving now. This can be used to find how fast the machine can move. The current speed may differ slightly from the set speed, especially at the start. This does not matter, as regulation ensures that the average speed within 10 metres is correct.
- START** Start machine delay. The machine start time can be delayed by up to 24 hours. To set the start time, press the **PROG** key 3 times, then set the time using the "+" and "-" keys.
- STOP** The time that irrigation is completed with a delayed start.
- OPERATING HOURS** Shows how many hours the machine has been running since the electronics started for the first time.

MENU 5

0m	30 . 0m/h	0m
0m	30 . 0m/h	0m
0m	30 . 0m/h	0m
0m	30 . 0m/h	0m

This menu is for irrigation at different speeds in zones of the lane.
 Press the **PROG** key 3 times to program the zones.
 See later chapter for details.

MENU 5

SIGNAL 23
NETWORK HOME
A: +45123456
B: +45234567

SIGNAL GSM signal strength.
 NETWORK GSM network
 A: First number on "SMS" list.
 B: Second number on "SMS" list.

See GSM chapter for details.

START:

The turbine can only start if the magnet is aligned with the end stop sensor (or end stop sensors). See menu 3 for control of the **STOP SENSOR**. Press the **START** key to turn on the water. The regulator valve for bypass around the turbine then closes. (Turbine starts). If the end stop sensor is not in place, only the main valve can be opened, which then immediately closes again. Used to relieve pressure before removing charge hose from hydrant.

DEFERRAL OF START TIME

First press the **STOP** key to shut off the water supply. Then press the **MENU** key 3 times and **PROG** 3 times. The start time can be set using the "+" and "-" keys. Finally, select pre- and post-irrigation. To exit, press **MENU**. Info: The clock can only be set forwards.

STOP:

When the magnet is removed from the end stop sensor, the turbine stops and the main valve shuts off the water (turns on the water at negative pressure). If post-irrigation is selected, rewinding stops when the magnet is removed from the sensor. When the post-irrigation time has elapsed, the main valve closes. When the **STOP** key is pressed, the turbine stops immediately and the main valve shuts off the water, regardless of whether post-irrigation is selected.

SUPERVISION:

Program Rain has a built-in supervision system. The supervision system will be activated if for any reason the machine has water in the same location for longer than a specified time. This time is factory-set to 20 minutes. If the time is set to 0, there is no supervision. (See constants on page 17 for setting the supervision time.) If speed supervision less than 50 % of pre-selection is required, select speed supervision together with the above time.

SPEED:

The speed is set using the "+" and "-" keys. First count up in steps of 0.1 m/h. After 10 steps, count up in steps of 1 m/h. The speed can be changed at any time during irrigation. If the speed changes during irrigation, the dose and time for the remaining irrigation will be calculated immediately based on the new speed.

PRE-IRRIGATION:

If pre-irrigation is required, press the **PRE-** key. The pre-irrigation time is calculated as 8 x the time to move 1 m at the current speed. The constant can be changed individually for pre- and post-irrigation. (See constants). If pre-irrigation is selected, the machine will move forward approx. ½ m, after which the machine will stop and stand still for as long as pre-irrigation is performed. Menu 2 shows the number of minutes remaining of the pre-irrigation time. If you want to cancel pre-irrigation, press the **START** key. This will cancel both pre- and post-irrigation and the turbine will start.

POST-IRRIGATION:

If post-irrigation is required, press the **POST-** key. The post-irrigation time is calculated as 8 x the time to move 1 m at the current speed. The constant "8" can be changed individually for pre- and post-irrigation. (See constants on page 17). Post-irrigation starts counting down when the magnet is removed from the stop sensor. When the stop sensor is activated, the turbine stops and post-irrigation starts counting down (see menu 2). When the post-irrigation time has elapsed, the main valve closes. (Opens in installations with negative pressure stops). For machines with mechanical end stops: The turbine stops when the stop sensor is activated. When the post-irrigation time has elapsed, the turbine starts and the machine moves to the mechanical end stop. Press **START** to cancel post-irrigation. If constant "8" (early stop) is selected, the machine will stop when it reaches the selected distance.

PROGRAMMING 4 DIFFERENT SPEEDS:

The hose must be unwound before programming, so the computer knows the number of metres in the irrigation lane. The following example assumes that the unwound hose is 400 m. Press the **PROG** key 3 times and the display will show:

400m	30.0m/h	0m
0m	30.0m/h	0m
0m	30.0m/h	0m
0m	30.0m/h	0m

The desired speed can now be selected, in this case 25.0 m/h. Press the **PROG** key and the display will show:

400m	25.0m/h	0m
0m	30.0m/h	0m
0m	30.0m/h	0m
0m	30.0m/h	0m

The desired distance can now be selected, in this case 300 m. Press the **PROG** key and the display will show:

400m	25.0m/h	300m
300m	30.0m/h	0m
0m	30.0m/h	0m
0m	30.0m/h	0m

Now that the first zone is programmed, apply the same procedure to all 4 zones. Zone 4 automatically ends at 0. When zone 4 is programmed, press the **PROG** key again and the display will show:

DELETE PRESS MENU
SAVE PRESS PROG

If **PROG** is pressed, the program is stored and irrigation will be performed according to this program.
 If **MENU** is pressed, the program is deleted and the speed is the same for the entire irrigation lane.

STATUS	Status messages in display
EMERGENCY:	Machine has not been started, anyway speed pulses is received and it is trying to maintain the speed requested.
RUNNING:	The machine is irrigating, and everything is working properly.
LOW PRESSURE:	Water pressure is below pressure switch treshold. Machine acts depending on Machine data.
STARTING:	Operator has pressed START key, and start sequens is in process.
START REMOTE:	Machine is starting due to an SMS .
START DELAY:	Machine is waiting for start delay to elapse. (See menu 4).
START PRESSURE:	Machine has started due to pressure rise. Machine is using pressure level, to start 2'nd machine on string. Operator is holding STOP key to prevent PRESSURE and REMOTE start.
START DENIED:	Machine has stopped due to operator STOP .
STOP USER:	Machine has stopped due to an SMS .
STOP REMOTE:	Machine has reached end and is stopped by STOP SENSOR .
STOP SENSOR:	Machine has reached distance for stop. (See constant for early stop).
STOP DISTANCE:	Machine has reached stop but waits nn Seconds to proceed stop sequence.
STOP DELAY:	Operator is pressing START key, preventing REMOTE stop.
STOP DENIED:	Machine has stopped due to supervision time is elapsed. Machine has not moved in nn minutes. (See constant for supervision time).
SUPERVISION TIME:	Machine opens valve, to force pressure drop, to stop main pompe. After 2 minutes, valve closes to prevent draining of pipes.
FORCE LOW PRES:	Machine is performing pre irrigation
PRE IRRIGATION:	Machine is performing post irrigation
POST IRRIGATION:	

There are different constants that can be set by the user.

These constant will be saved for years even if the battery is disconnected.

Programming procedure:

The speed should be adjusted to **11.1 m/h** to reach the constants.

Press rapidly the **PROG** key 3 times to gain access to change the constants.

Then by pressing the **PROG** key, it steps forward to the constant, which should be altered.

With the "+" and "-" keys the constant value can be changed. Press the **MENU** key to save, and the Program Rain display goes back to normal. If the **MENU** key is not pressed, the Program Rain switches back to normal after 1 minute, and the changes of the constants are not saved.

Cons no.	Note	Fact. Adj.	Min. Value	Max. Value	Description
0		100	-	-	Enter 111 to reach machine data
1		00:00	00:00	23:59	Time in line 2 is set
2		8	1	15	Pre irrigation
3		8	1	15	Pre irrigation
4		20	0	99	Supervision time [minutes]
5		1	1	15	1 English, 2 Danish, 3 German, 4 French, 5, Dutch 6 Swedish, 7 Spanish, 8 Italian, 9 Polish, 10 Japanese 11 Hungarian
6		0	0	2	0 = Stop for high pressure slow shutdown 1 = Stop for low pressure. valve opens and close again after 3 minutes 2 = Motor for stop disconnected
7		-	0	1000	Actual distance, can be set by the keyboard [m]
8		0	0	1000	Early stop [m] (* Is only performed when Post Irrigation is selected *)
9		0	0	1000	Post irrigation before stop [m]
10		0	0	1000	Distance for alarm [m] (* Disabled if Machine data 22. Sprinkler, is selected *)
11		40	5	120	Water flow [m ³ /h]
12		60	5	100	Spacing between irrigation lanes [m]

Constant nr. 11 (the code) is set to 111 to enter the machine data.
Then press **PROG** and the machine data is shown.

The user can change the following machine data:

Machine data Number of flashing digits		Possible setting	Factory settings
0	Hose length	0 - 1,000m	Not used
1	Hose diameter	40 - 200 mm	Not used
2	Hose drum int. Diameter	500 - 3,000 mm	Not used
3	Number of hose turns per layer	5.00 - 30.00	Not used
4	Large gear on hose drum	50 - 1000	Not used
5	Small gear on gearbox	5 - 40	Not used
6	Number of magnets	1 - 20	Not used
7	Ovality compared to 100 %	0.70 - 1.00	Not used
8	Length of first pulse to stop valve	0 - 45 sec.	3
9	Length of subsequent short pulses to stop valve	0 - 300 m/sec.	160
10	Time between short pulses to stop valve	1 - 5 sec.	2
11	Number of short pulses to stop valve	0 - 250	100
12	Mechanical stop (with only 1 motor) Electrical stop (closed low pressure) even if the pressostat registers low pressure	0	1
		1	
13	Length of pulse to regulator motor at start-up (Oil pump Motor 1)	26.1 - 0.9 sec.	4.5
14	Pressostat not connected Pressostat connected (to start/stop) or Radio start Pressostat installed: (can be used (for start only) for 2 machines on the same system, Autostart with special pressostat.)	0	1
		1	
		2	
15	Length machine moves per pulse: 0 = Moves according to formula FM4300 & FM4300H = 73.5 mm (2 magnets) FM4300 & FM4300H = 38.8 mm (4 magnets) FM4400 & FM4400H = 46.2 mm (4 magnets) Old Rear axle assembly FM4400 & FM4400H = 46.0 mm (4 magnets) New Rear axle assembly FM4500 & FM4500H = 85.0 mm (2 magnets) FM4500 & FM4500H = 42.5 mm (4 magnets) FM4550 & FM4550H = 46.2 mm (4 magnets) Old Rear axle assembly FM4550 & FM4550H = 46.0 mm (4 magnets) New Rear axle assembly FM4800H = 43.3 mm (4 magnets) Old Rear axle assembly FM4800H = 46.0 mm (4 magnets) New Rear axle assembly FM4900H = 103.0 mm (2 magnets) FM4900H = 51.5 mm (4 magnets) FM4900H = 46.8 mm (4 magnets) New Rear axle assembly FM5500H = 47.0 mm (4 magnets) FM5500H = 47.0 mm (4 magnets) New Rear axle assembly 62.5 = When moving with roller Ø80 [mm] 0 = Moves according to formula (with data number 0 to 7)	0 - 160.0 mm	
16	Speed sensor 0 = Round sensor for roller 1 = Double sensor	0 1	1
17	Opening of inlet valve 0 = Quick opening 1 = Slow opening	0 1	0
18	Pressostat 0 = Inlet remains open at low pressure 1 = inlet closes at low pressure	0 1	0
19	Delay from stop sensor to turbine stopping (sec)	0	0

The user can change the following machine data:

40		0	0	2	Analog Pressure gauge 0 = Digital switch 1 = Analog pressure gauge – Display units [BAR] 2 = Analog pressure gauge – Display units [PSI]
41		0.50	0,10	5.00	Voltage Offset [V]
42		0.20	0,05	5.00	Voltage gain [V]
43		3.5	0,0	25.0	Pressure setpoint 0.0 –25.0 [BAR] Pressure level for Off – On
44		0.2	0.2	25.0	Pressure hysteresis 0.2 – 25.0 [BAR] Setpoint - 0.5* hysteresis for Off Setpoint + 0.5* hysteresis for On Default settings 0.2 <ul style="list-style-type: none"> • 3.4 BAR = Off • 3.6 BAR = On

The Program Rain can be adjusted to 2 different types of sensors.

See Machine Data #16 Sensor

One is a round sensor 60 mm in diameter and 4 sensors inside; this is only for rollers with one magnet. When the battery is connected the display for 2 sec. shows VERSION n. n0.

The other is a square sensor, or 2 separate sensors; this is used for rollers with more than one magnet and for discs with 1 to 20 magnets. When the battery is connected, the display will show VERSION n. n1. for 2 sec.

Cable connection

Double sensor.			Round sensor		
Program Rain 10 18 Pol Connector			Program Rain 10		
Cable connection	Version n.n1	Double sensor	Cable connection	Version n.n0	Round sensor
1 + Battery	Brown	12 V	1 + Battery	Brown	12 V
2 - Battery	Blue		2 - Battery	Blue	
3 + Solar Panel	Brown		3 + Solar Panel	Brown	
4 - Solar Panel	Blue		4 - Solar Panel	Blue	
5 Motor 1	Speed Regulation		5 Motor 1	Speed Regulation	
6 Motor 1	Speed regulation		6 Motor 1	Speed regulation	
7 Speed Sensor 1 *	Blue		7 Speed Sensor	Blue	
8 Speed Sensor 1 *	Black		8 Speed Sensor *	Black	
9 Speed Sensor 2 *	Yellow/green		9 Speed Sensor *	Yellow/green (Red)	
10 Speed Sensor 2 *	Brown		10 Speed Sensor	Brown	
11 Stop Sensor	Blue or Brown		11 Stop Sensor	Blue or Brown	
12 Stop Sensor	Blue or Brown		12 Stop Sensor	Blue or Brown	
13 Motor 2		Stop Motor	13 Motor 2		Stop Motor
14 Motor 2		Stop Motor	14 Motor 2		Stop Motor
15 Pressure	Blue or Brown		15 Pressure	Blue or Brown	
16 Pressure	Blue or Brown		16 Pressure	Blue or Brown	
17 - BIP			17 BIP -		
18 + BIP	Brown	Sprinkler	18 BIP +	Brown	Sprinkler
Motor 3	Blue	Sprinkler	Motor 3	Blue	Sprinkler
* If the distance counter count the wrong way, the speed sensor should be turned.			* If the distance counter count the wrong way, the cable on terminal 8 and 9 must be interchange.		
Program Rain 10 6 Pol Connector					
19 + GSM	Brown	+12 V			
20 - GSM (-Pressure)	Blue (Green)				
21					
22					
23 + Pressure	Brown	+12 V			
24 Pressure Signal	White	0-5V			

Technical data

Dimensions (h*b*d)	170*140*100 [mm]
Voltage	10-15V dc
Current	6 mA (Idle) 30 mA (with GSM) 80 mA (Light)
	5A motor mas. current
Fuse	5A Fast

Fault localisation.

?

The turbine can not start by pressing START. Pre-and post-irrigation can not take place.

Answer:

Magnet for stop-sensor is not on its place, or cable or sensor is damaged.

Stop sensor: The mark must be on when the magnet is on place, and it disappears when the magnet is removed. See menu 3.

A damaged cable can be repaired but absolutely watertight. At least encapsulated in epoxy.

But a new sensor and cable is recommend.

If pressure sensor is used there must be pressure on the water. The mark for pressure must be on. ■

?

No digits in the display.

Answer:

Battery interrupts. Fuse inside the box is blown. The fuse is for wrong connection of + and -

From the factory there are an extra fuse on a single fuse-holder on the printed circuit.

Fuse 5 A. Battery electric voltage 12 V. See menu 2.

?

The clock shows 00:00.

Answer:

If the power has been interrupted the clock will go to zero. Therefore instead of showing the finishing time it is the number of hours and minutes to the irrigator is finished that is shown. If the clock is set the time to the irrigator has finished will be show. See setting the clock.

?

Distance meter is not correct and the speeds not correct.

Answer:

See after damaged cable or sensor. The 2 marks must during pulling out the tube appear in order from the left as following: The first appear the second appear the first disappear the second disappear. During retraction it must go in opposite order. See menu 3 speed sensor. ■ ■

?

Only maybe the half or 2/3 of the real length is counted up.

Answer:

The stop mechanism can be activated a short time by hopping of the tube or if the windings around the drum are losing. It can cause the magnet removed from the stop sensor a short moment. It will set the counter to zero.

In spite of the meter of the tube is not correct the irrigator will run to the end and stop normal. But incorrect speed depends of the incorrect registration of the actual layer. If wanted the correct number of metre can be set in. See CONSTANT no 7.

The most used combination of different constants:

With constants factory adjusted the machine always will run. But there are different conditions from farm to farm and there are also different wishes from the farmer. Therefore some constants can be adjusted for local wishes.

1. **Slow start of turbine.**

Machine data no. 13 is adjusted to 2-4 to start. Now the valve for control of speed will close about half and continue stepwise until the adjusted speed are reached. Correct adjustment is: Continuously closing of the valve until the turbine is start running and stepwise until adjusted speed is reached.

2. **Slow opening for inlet of water.**

Machine data no. 17 is set to 1. Opening for the water will be stepwise.

3. **Only 1 motor for speed regulation.**

Machine data no. 12 is set to 0. Post irrigation will take place as following: When the stop sensor is activated the turbine stops. After the time for post irrigation the machine start again and run to the mechanic stop.

4. **Start up of no. 2 machine when no. 1 machine reaches the stop**

Machine data no. 14 is set to 2. Both machines must be equipped with adjustable pressure switch. Adjust the pressure switch to a point between normal pressure and the pressure when the pump will stop. For instance: Normal pressure can be 7 bar and pressure for pump stop 9 bar. Adjust the pressure switch to 8 bar on both the machines. Start no. 1 machine as normal by pressing start. Set up no. 2 machine but press stop. When no. 1 machine comes to slow close down, no. 2 machine will start up when the pressure reach 8 bar. Please note that if the field's height difference is too large, the necessary pressure differences, the pressure switch may be set to be too large

5. **Stop the machine because of low pressure and pressure switch mounted.**

Constant no. 6 is set to 1 and machine data no. 12 must be set to 2. (=Stop motor from turning in opposite direction.) It means that with the same cable connection to the motor, the valve will open instead of closing for stop. After 2 minutes the valve closes again, otherwise it is impossible to obtain pressure to start. When machine data 12 is 2, the valve only opens in connection with the stop-sensor, stop-button and supervision. But not when the pressure switch is turned off.

6. **Pre-irrigation before the gun reaches the stop.**

Constant no 9 can be set to the number of meters; you want the gun to stop before the end stop. Now post irrigation should take place before the pipe starts lifting the gun wagon, which causes a wrong position of the gun. This can be up to 15 meters before the end stop. The drive stops within post irrigation and then run to normal stop.

GSM-2G

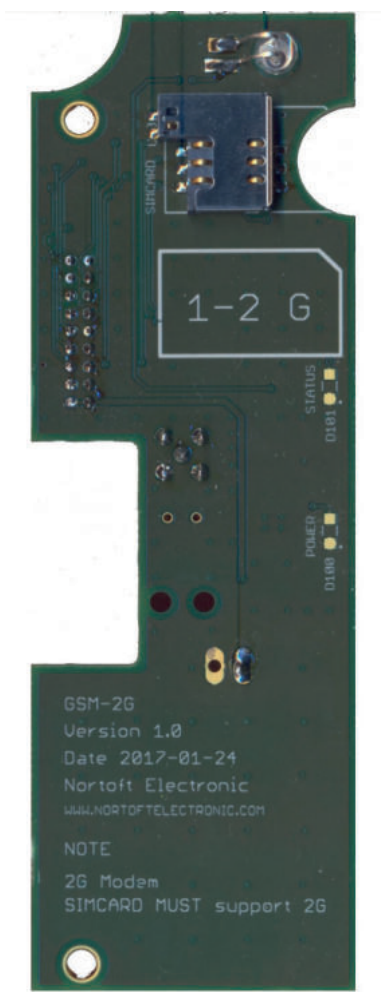

Features	Modem
<p>Easy mount on PR10-12</p> <p>Low power consumption</p> <p>Total of 10 mA, PR10-12 and GSM-2G Visible LED for Status</p> <p>Includes</p> <p>Antenna with 2 meter cable.</p> <p>All fittings for mounting.</p>	<ul style="list-style-type: none"> • Dual-band 850/900/1800/1900MHz • GPRS multi-slot class 12/10 • GPRS mobile station class B • Compliant to GSM phase 2/2+ - Class 4 (2 W @850/900MHz) - Class 1 (1 W @1800/1900MHz) • Operation temperature:-40°C ~85°C

GSM

GSM-2G is a GSM modem made for PR10-12.

rrigator, can be Started, Stopped, or requested for status, only by sending an SMS.

Commands

Start Starts machine.
Stop Stops Machine
Speed ### Set the **Speed** whitin 3..400 m/h. eg.
Status Gets the current status of machine.

SMS can be typed in both upper- or lower case or mix.

If you call the modem, from a GSM telephone, you will recieve an SMS containing Status

Status

SPEED	30.0m/t	SMS, Sent by PR10, contains information about Irrigation
DOSE	22 mm	
TIME 14:10	STOP 18:16	
STATUS	RUNNING	
DISTANCE	123m	
BATTERY	12.8V	
CHARGER ON	0.231A	

SMS is sent on:

LOW PRESSURE: Start the pump, so you get pressure on the machine.
STOP SENSOR: The machine is ready to be moved to a new field.
STOP REMOTE: The machine is stopped using SMS
STOP DISTANCE: The machine has reached stop point. (Constant 8)
SUPERVISION TIME: The machine has not moved, for nn minutes (Constant 4), due to a malfunction.
Check the machine before continuing.

How to get started:

Disconnect Electronic from Battery.

Put in the SIM card into an ordinary mobile phone and change the pin code to 1111.
Try to send at receive an SMS, on phone, to verify the SIM card and account is working properly.

Mount the modem on PR10-12 using the threaded spacers.

Insert the SIM card into the modem.

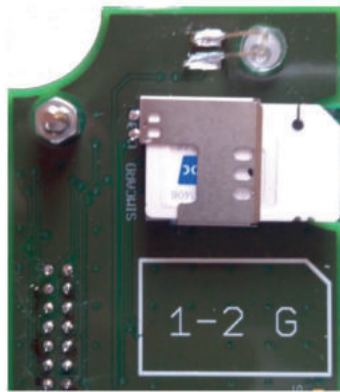

Connect the power and setup machine data #30

- 0 = GSM Disabled
- 1 = GSM Enabled, all telephone number is allowed.
- 2 = GSM Enabled, only telephone number on SMS list.

See manual for changing machine data.

SPEED 11.1m/h
DOSE 22 mm
TIME 14:10 Stop 7:43
M.DATA 30 1

After Approx. 30-45 seconds moden should be connected to network.

SIGNAL 23
NETWORK HOME
A: +45123456
B: +45234567

Signal strength, 0 – 31, and network should show up in display menu #6
 A Signal strength at 10 og higher to work properly.
 A Signal strength at 99 indicates signal error.

Modem har LED der viser status.

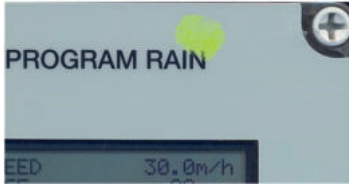

GREEN

POWER DOWN

- Network search or
- No SIM card is inserted
- No PIN is entered
- No GSM network is available

STANDBY

(registered in the network)

Connection (TALK)

LED

Off

Flashes rapidly

Flashes slowly

On

When an SMS is Received, following is showed on Display:

```

Receiving SMS
#: +45123456
Status
    
```

Receiving SMS, Incoming phone number and 40 character of message, Any SMS can be received, but only known commands are accepted.

When an SMS is Sent, following is showed on Display:

```

Sending SMS
#: +45123456

Status Running
    
```

Sending SMS, Outgoing phone number and current machine status.

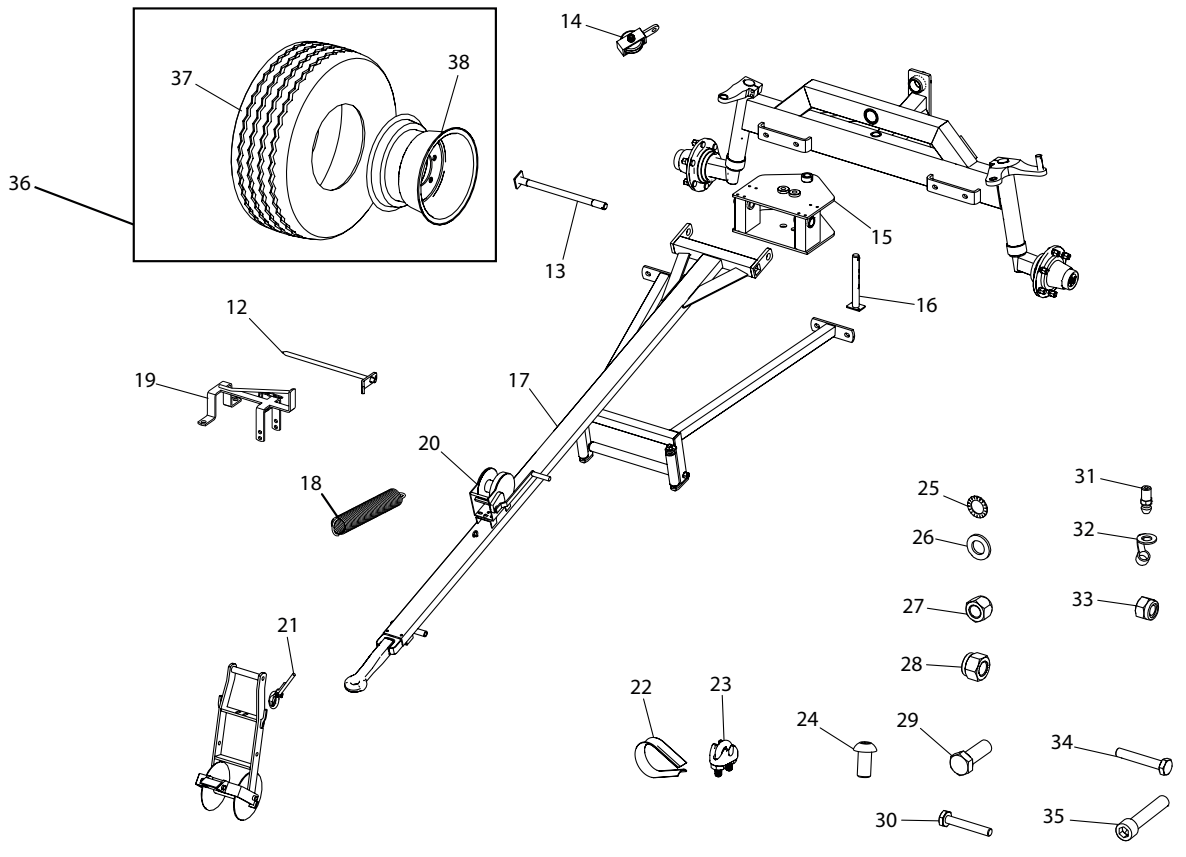
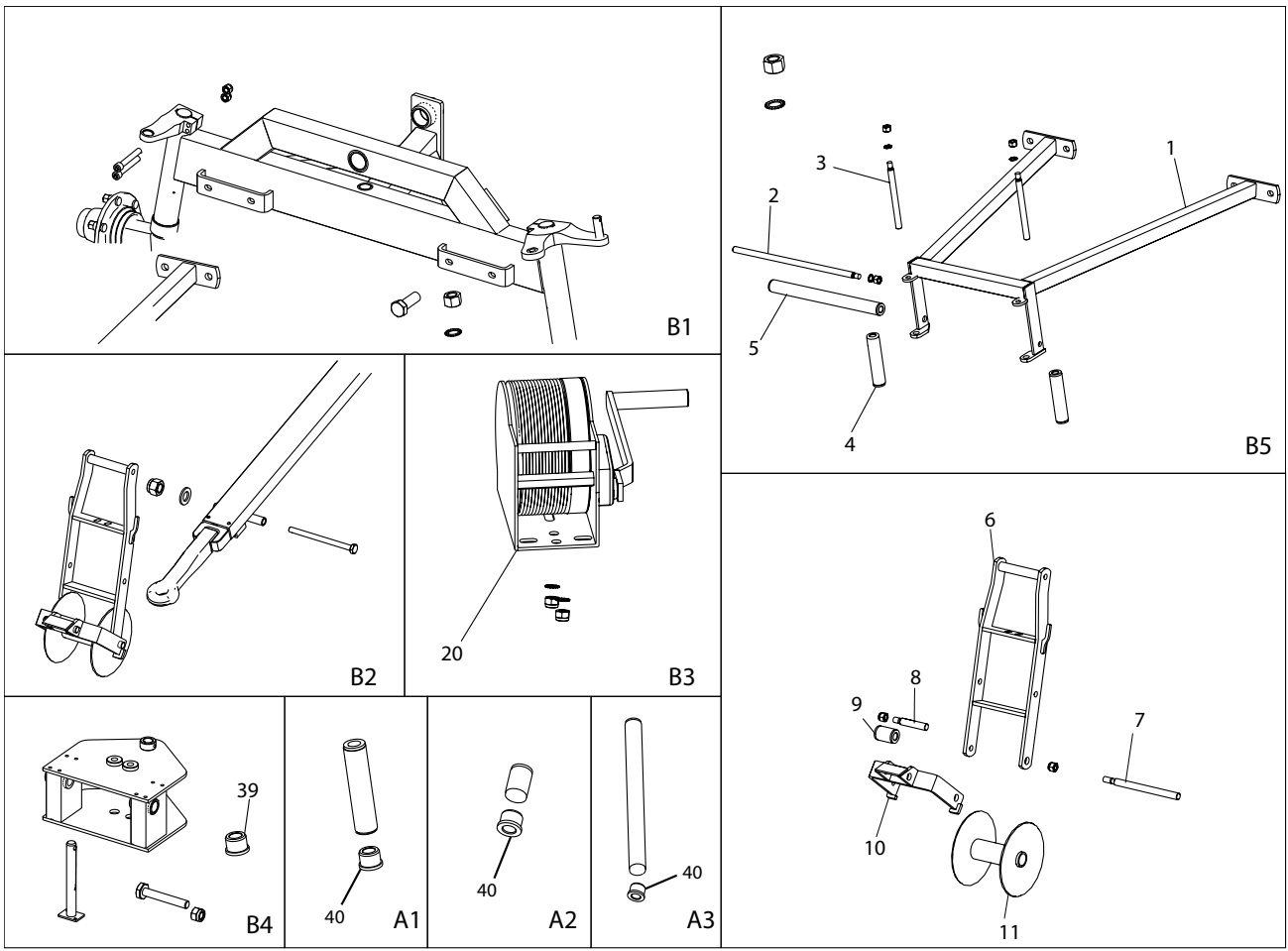

Item no.	Part no.	Qty	Description	Comments
1	1010107	1	Front hose guide	
2	1761026	1	Shaft	
3	761025	2	Shaft	
4	761023	2	Support roller 5/4 170 mm	A1
5	1761024	1	Support roller 5/4	A3
6	1008210	1	Bracket for steering wheel	
7	1008218	1	Shaft	
8	761273	1	Shaft 115 mm	
9	761272	1	Support roller 5/4 50 mm	A2
10	1008215	1	Safety stop	
11	1008205	1	Steering wheel	
12	1001255	2	Ground spike	
13	1008222	1	Horizontal split pin	
14	761015-10	1	Cable roller	
15	1009170	1	Drawbar bracket	
16	1008220	1	Vertical split pin	
17	1008200	1	Drawbar	
18	2003929	1	Spring	
19	1761006	1	Wheel chock	
20	505500	1	Winch	
20	762036	1	Complete wheel with cable	
21	1007812	1	Cable Ø5 x 7700 mm	
22	761012-1	1	Cable thimbles	
23	761013-1	3	Cable lock	
24	095010020	2	M10 x 20 Round head	B3
25	763916	8	M16 Riplock	B1 & B5 & B2
26	050316	4	M16 Plain washer	B1
27	040416	7	M16 Steel nut	B1 & B5 & B2
28	044012	4	M12 Lock nut	B1
29	022216045	4	M16 x 45 Steel bolt	B1
30	021010065	1	M10 x 65 Steel set bolt	B4
31	761286	1	Lubrication nipple	
32	761286-2	1	Lubrication nipple Cap	
33	044010	3	M10 Lock nut	B3
34	021016230	1	M16 x 230 Steel set bolt	B2
35	030512085	4	M12 x 85 Int. hex	B1
36	1008750	1	Comp wheel	
37	1008752	2	Wheel	
38	1008756	2	Rims	
39	1008226	2	Collar bushing	
40	761271	6	Nylon bearing for Support roller	
41				
42				

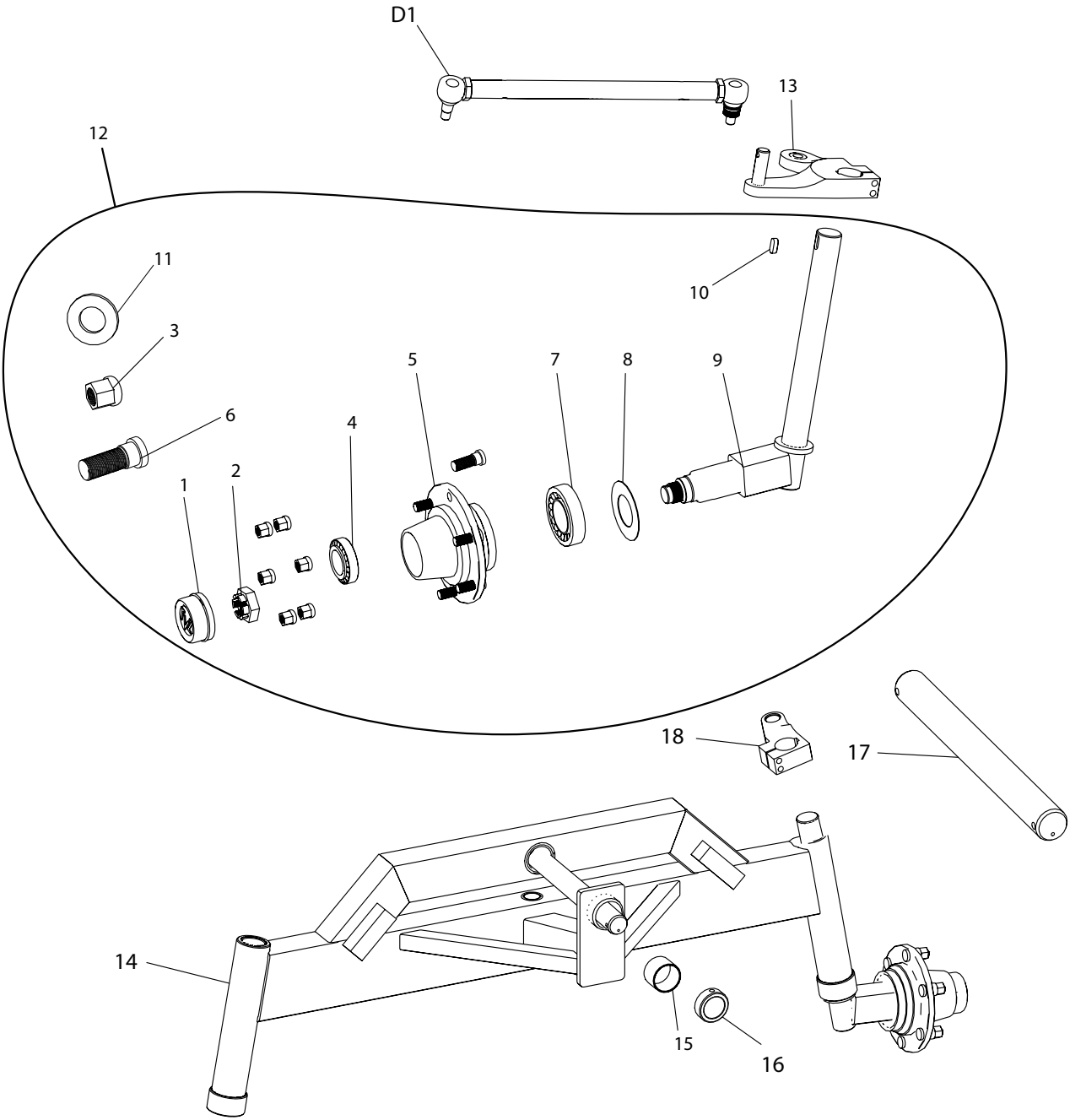
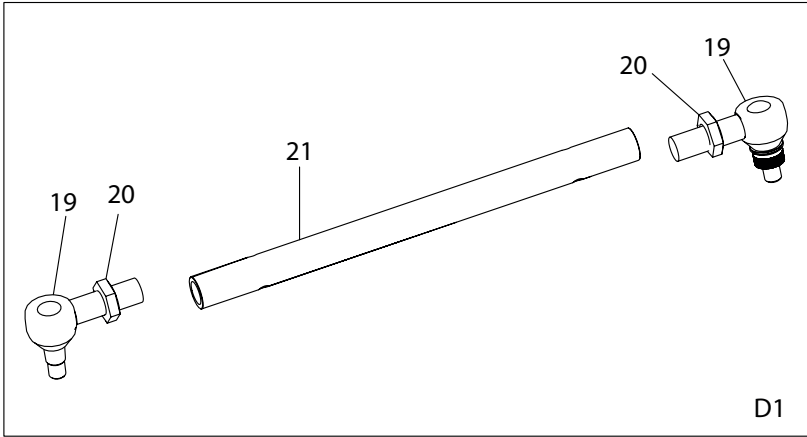

Item no.	Part no.	Qty	Description	Comments
1	1009181-6	2	Hub cap	
2	1009181-5	2	Crown nut	
3	1009181-4	12	Hub nut M18	
4	750032210	2	Tapered roller bearing	
5	1009181	2	Hub	
6	1009181-3	12	Hub bolt M18	
7	750032213	2	Tapered roller bearing	
8	1009181-7	2	Sealing washer	
9	1009185	2	Spindle	Left
10	1009188	2	Feather key	
11	1008198	5	Spacer washer for Shaft	
12	1009183	2	Spindle comp with Hub	
13	1009191	1	Spindle arm	
14	1007625	1	Front axle	
15	1008101	3	Bushing	
16	1008195	1	Stop ring	
17	1007629	1	Shaft for front axle	
18	1009192	1	Spindle arm Right	
19	1008155	4	Balljoint	
20	1008157	4	Locknut	
21	1009196	2	Track rod	

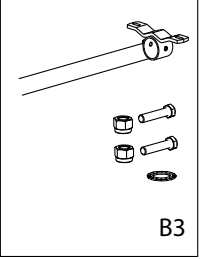
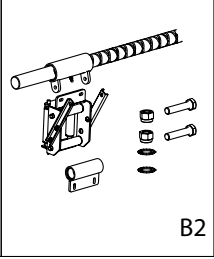
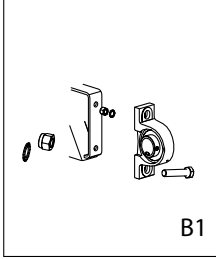
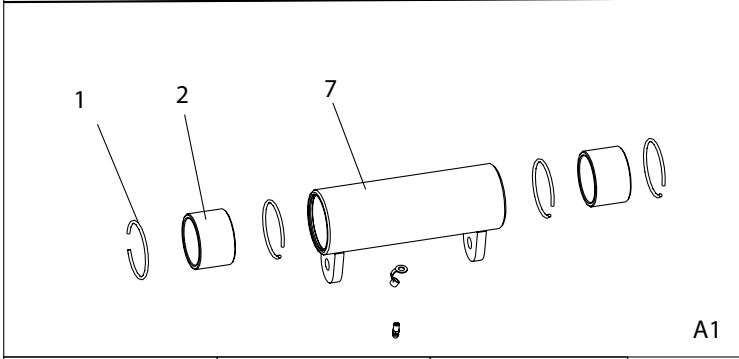
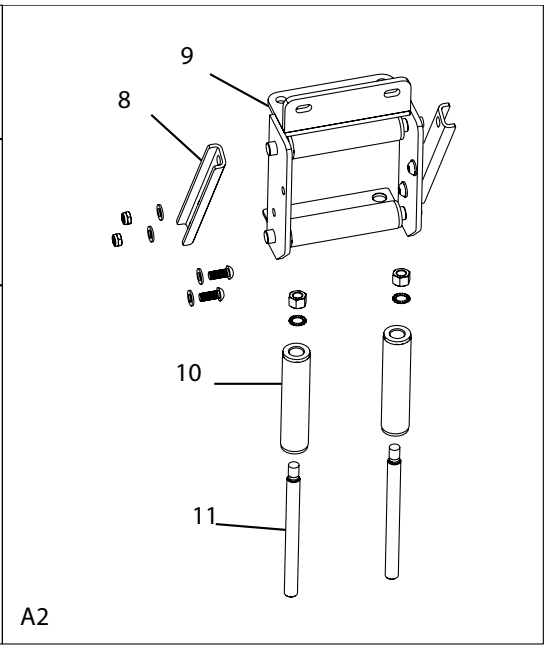
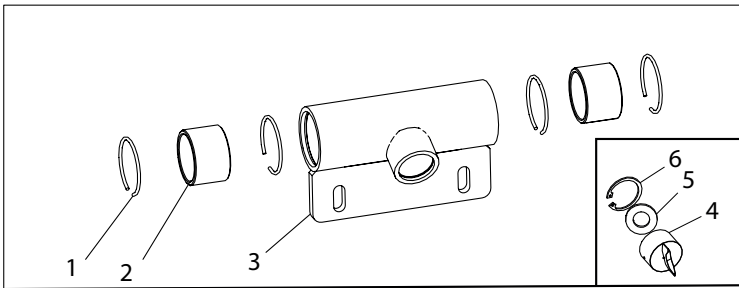

- 12 — [part]
- 13 — [part]
- 14 — [part]
- 15 — [part]
- 16 — [part]
- 17 — [part]
- 18 — [part]
- 19 — [part]
- 20 — [part]
- 21 — [part]
- 22 — [part]
- 23 — [part]
- 24 — [part]

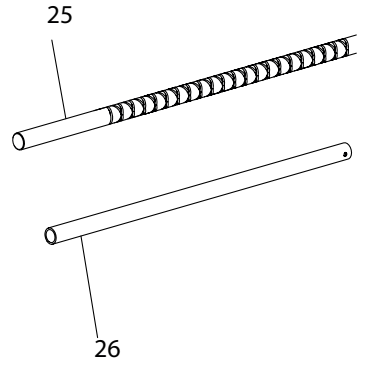
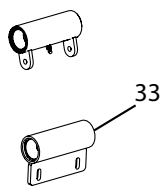
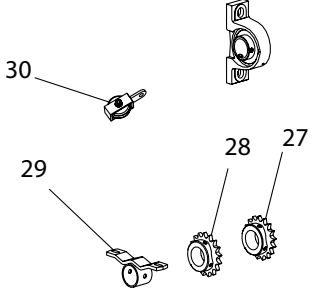
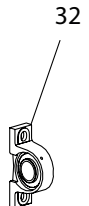
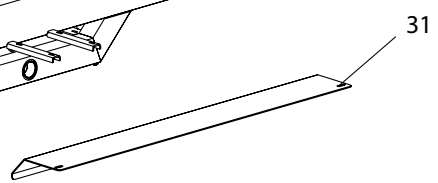
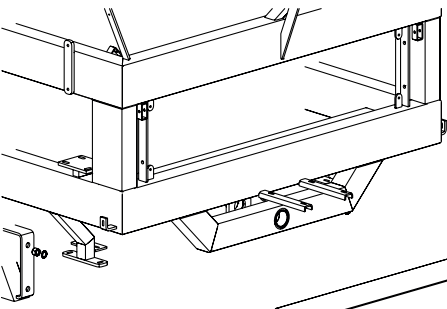

Item no.	Part no.	Qty	Description	Comments
1	761329	8	Retaining ring	A1
2	761293	4	Bushing	A1
3	761282-1	1	Guide sleeve	
4	761283	1	Guide shaft (Pin)	
5	761284	1	Washer	
6	701042	1	Int. Retaining ring	A1
7	1008475	1	Sleeve for support pipe carriage	
8	1008490	2	Brace for carriage	
9	1008480	1	Carriage for support pipe	
10	761023	4	Support roller	
11	761025	4	Shaft	
12	761286-2	1	Cap for lubrication nipple	
13	761286	1	Lubrication nipple	
14	050316	4	Plain washer M16	B1
15	763916	8	Riplock M16	B1 & A2
16	763912	4	Riplock M12	A2 & B2 & B1 & B3
17	044010	1	M10 Lock nut	B3
18	044012	12	M12 Lock nut	A2 & B2
19	040416	8	M16 Steel nut	A2 & B1
20	021010075	1	10 x 75 Steel bolt	B3
21	022216050	4	16 x 50 Steel set bolt	B1
22	022212030	4	12 x 30 Steel set bolt	B3
23	022212055	2	12 x 55 Steel set bolt	B2
24	095012035	4	M12 x 35 Round head	A2
25	1008470-1	1	Cross track shaft	
26	1008492	1	Support pipe for hose guide	
27	1001290	1	Sprocket 100 mm	
28	761290	1	Sprocket 110 mm	
29	1008485	2	Holder for support pipe	
30	761015-10	1	Cable roller	
31	2351078	1	Guard over worm shaft	
32	761289	2	Pillow block	
33	761282	1	Comp set Guide sleeve	

Qty	Description	Comments
22	M6 x 12 Int. Hex	
18	M6 Plain washer	
22	M6 Lock nut	
2	Door holder	
2	M6 x 25	

A1

Qty	Description	Comments
25	M6 x 12 Int. Hex	
18	M6 Plain washer	
25	M6 Lock nut	
2	Door holder	
2	M6 x 25	

A3

Qty	Description	Comments
22	M6 x 12 Int. Hex	
18	M6 Plain washer	
22	M6 Lock nut	
2	Door holder	
2	M6 x 25	

A2

Qty	Description	Comments
20	M6 x 12 Int. Hex	
18	M6 Plain washer	
20	M6 Lock nut	
2	Door holder	
2	M6 x 25	

A4

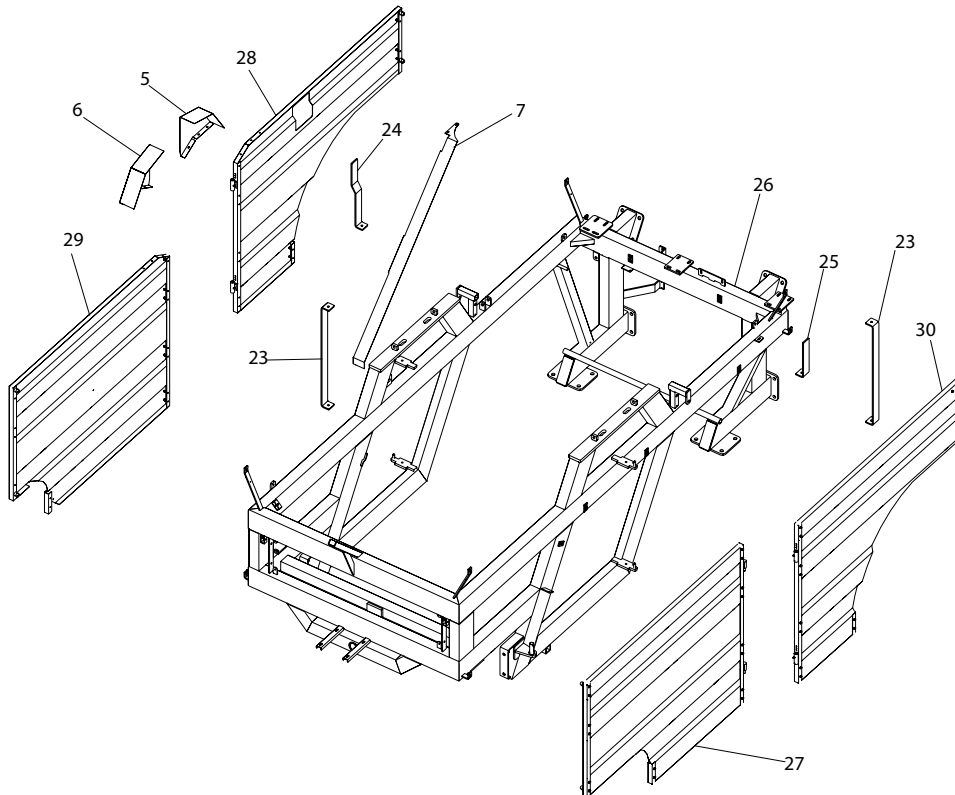
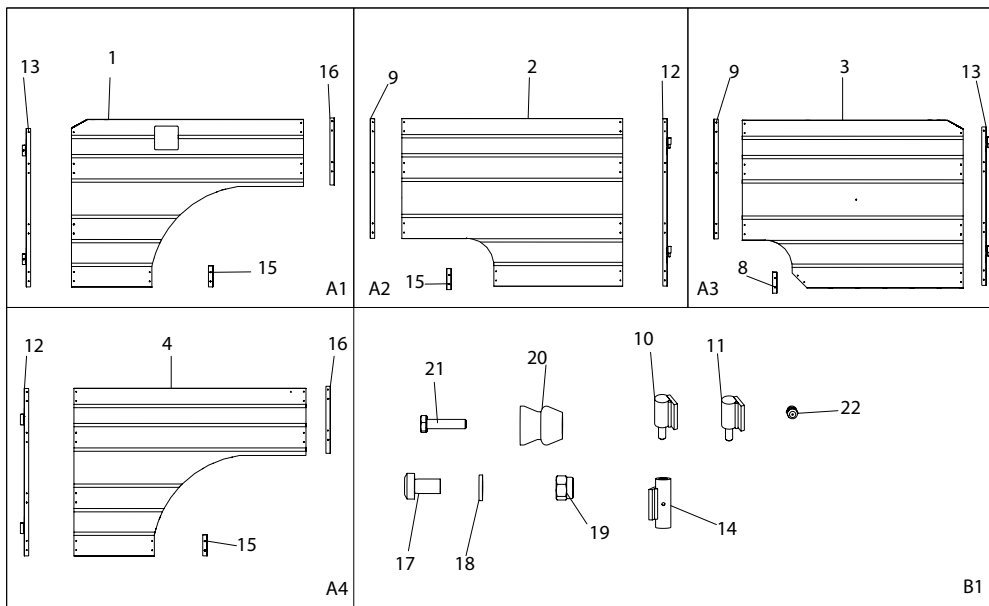

Item no.	Part no.	Qty	Description	Comments
1	2003084	1	Side guard RB	
2	2003092	1	Side guard LF	
3	2002965	1	Side guard RF	
4	2003093	1	Side guard LB	
5	2003091	1	Chain guard R	
6	2003089	1	Chain guard L	
7	2003099	1	Chain guard	
8	2003473	1	Edge profile	
9	2003118	2	Edge profile	
10	2003129-1	2	Left Hinge	
11	2003128-1	2	Right Hinge	
12	2003088	2	Edge profile	
13	2003386	2	Edge profile	
14	2003127-1	4	Hinge	
15	2003121	3	Edge profile	
16	2003119	2	Edge profile	
17	763726	89	M6 x 12 Int. Hex	B1
18	050306	72	M6 Plain washer	B1
19	095906	89	M6 Lock nut	B1
20	1327102021	8	Door holder Male	B1
21	022206025	8	M6 x 25	B1
22	761286	2	Lubrication nipple	A1 & A4
23	2003290-1	2	Bracket for centre console	
24	2003243-1	1	Bracket for guard	
25	2003242-1	1	Bracket for protective guard	
26	2006620	1	Frame	
27	2003122	1	Guard L Front	A2
28	2003124	1	Guard R Back	A1
29	2003125	1	Guard R Front	A3
30	2003123	1	Guard L Back	A4

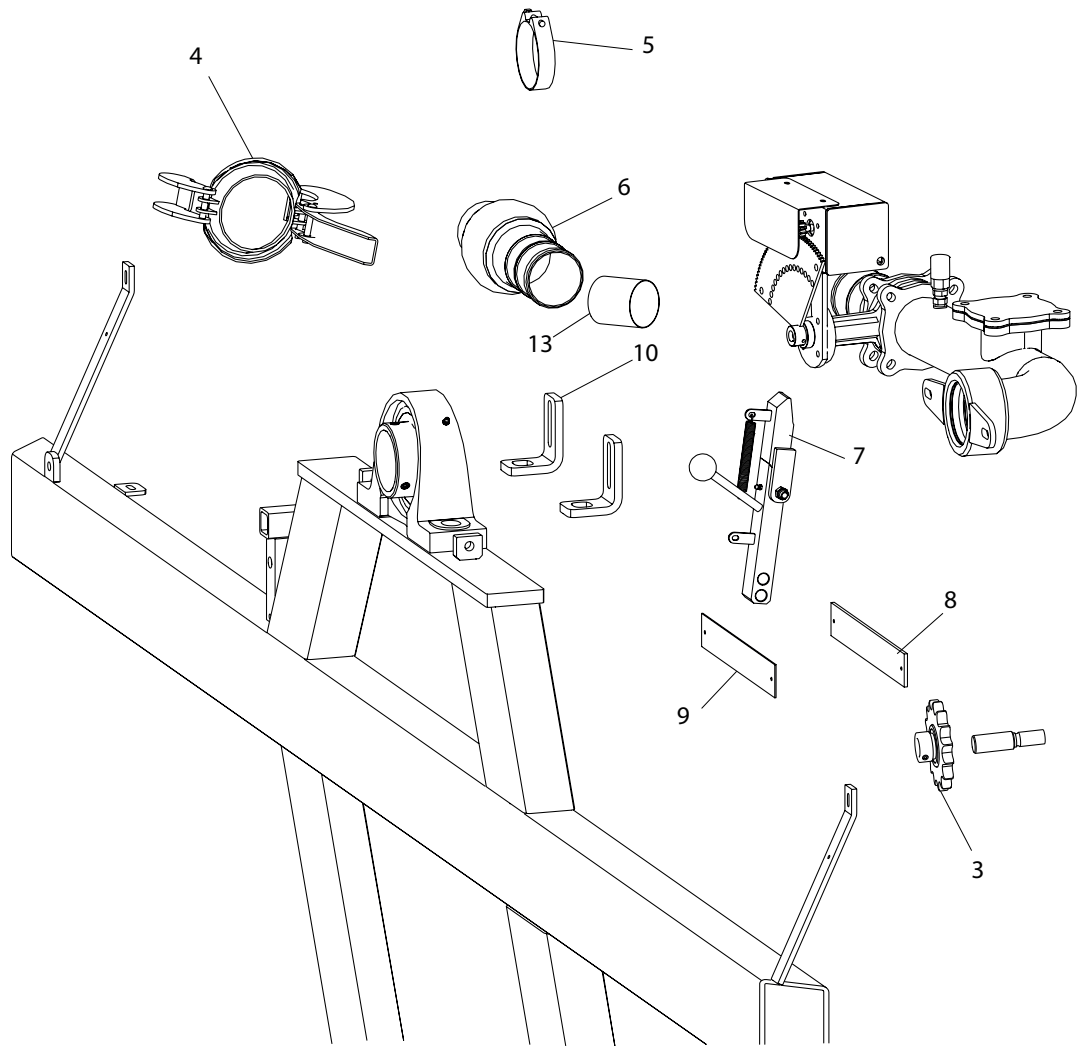
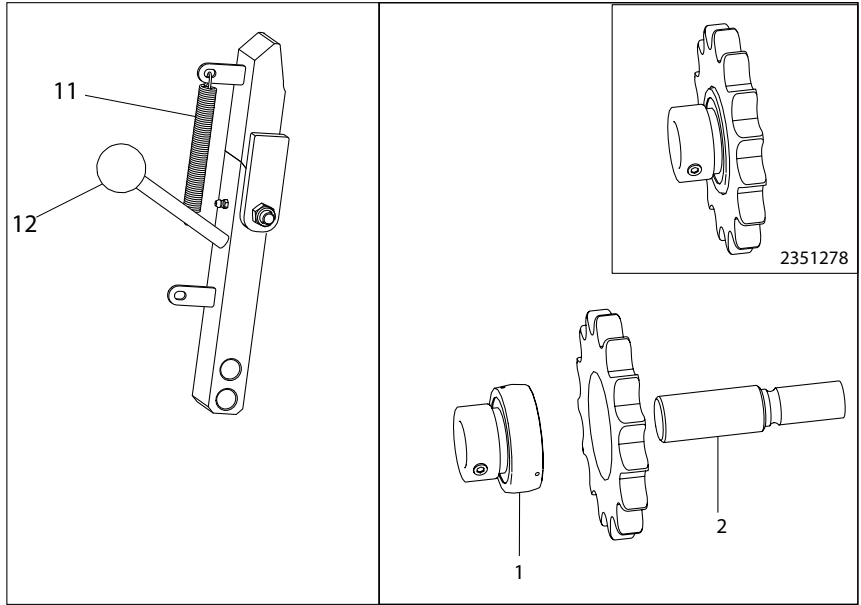

Item no.	Part no.	Qty	Description	Comments
1	761276	1	Bearing	
2	761275	1	Shaft	
3	2351278	1	Sprocket	
4	14050013	1	Locking ring	
5	16200726	2	Hose clamp	
6	1009290	1	HK ball with hose connector	
7	1008260	1	Locking pawl	
8	1007760	2	Slide plate 5 mm	
9	1008378	2	Slide plate 2mm	
10	1001087	4	Angle bracket	
11	570114	1	Drawbar spring	
12	763300	1	Ball lever	
13	16050210	1	Soft hose no. per running metre.	930 mm

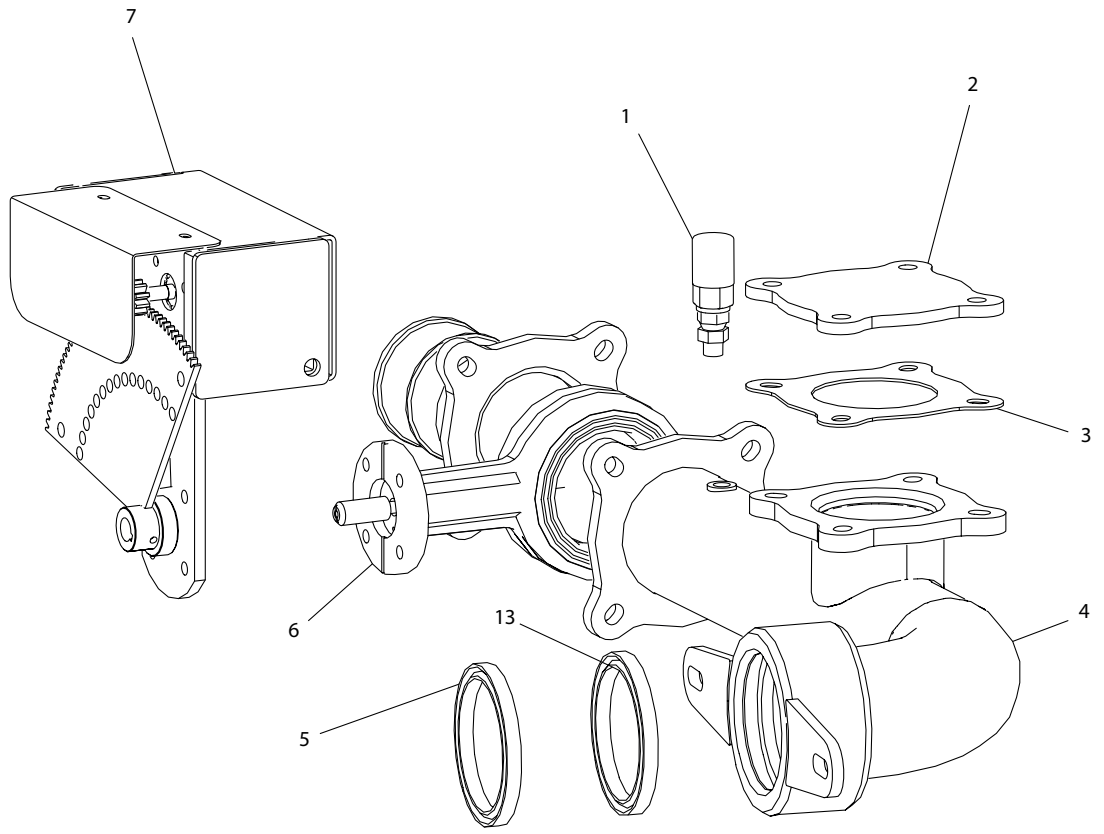
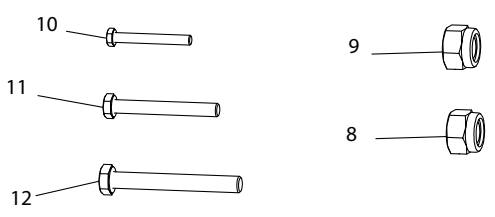
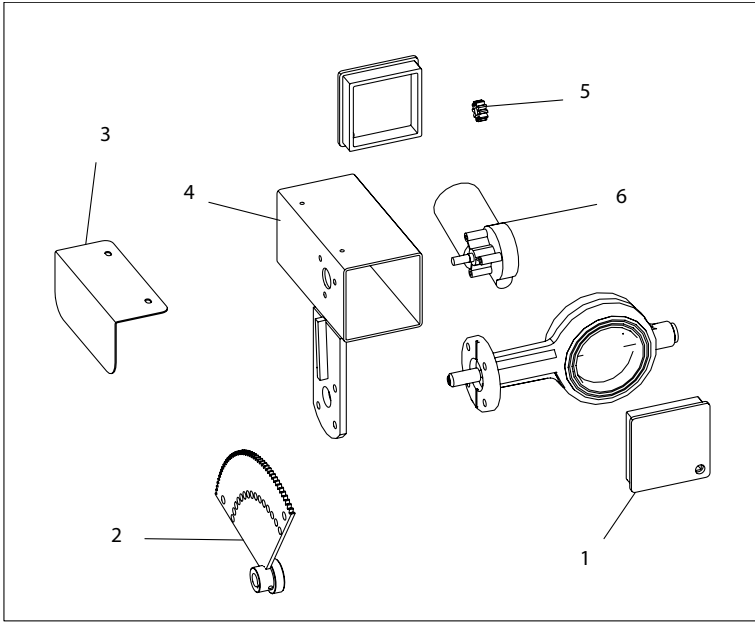

Item no.	Part no.	Qty	Description	Comments
1	1007545	1	Pressostat	
2	1007098	1	Blind flange	
3	631112	1	Flange gasket	
4	1009295	1	Head with pipe and flange	
5	1001095	1	Sealing ring	
6	1007250	1	Butterfly valve	
7	1007230	1	Comp motor valve	
8	044008	4	M8 Lock nut	
9	044010	8	M10 Lock nut	
10	021008035	4	M8 x 35 Steel bolt	
11	022210040	4	M10 x 40 Steel set bolt	
12	021010085	4	M10 x 85 Steel bolt	
13	1102138	1	Sealing ring	

Parts list 1007230

Item no.	Part no.	Qty	Description	Comments
1	1007175	2	End plug	
2	1007195	1	Gear for valve	
3	1007185	1	Guard for motor valve	
4	1007171	1	Motor housing	
5	1007190	1	Gear for motor	
6	1007180	1	Motor	

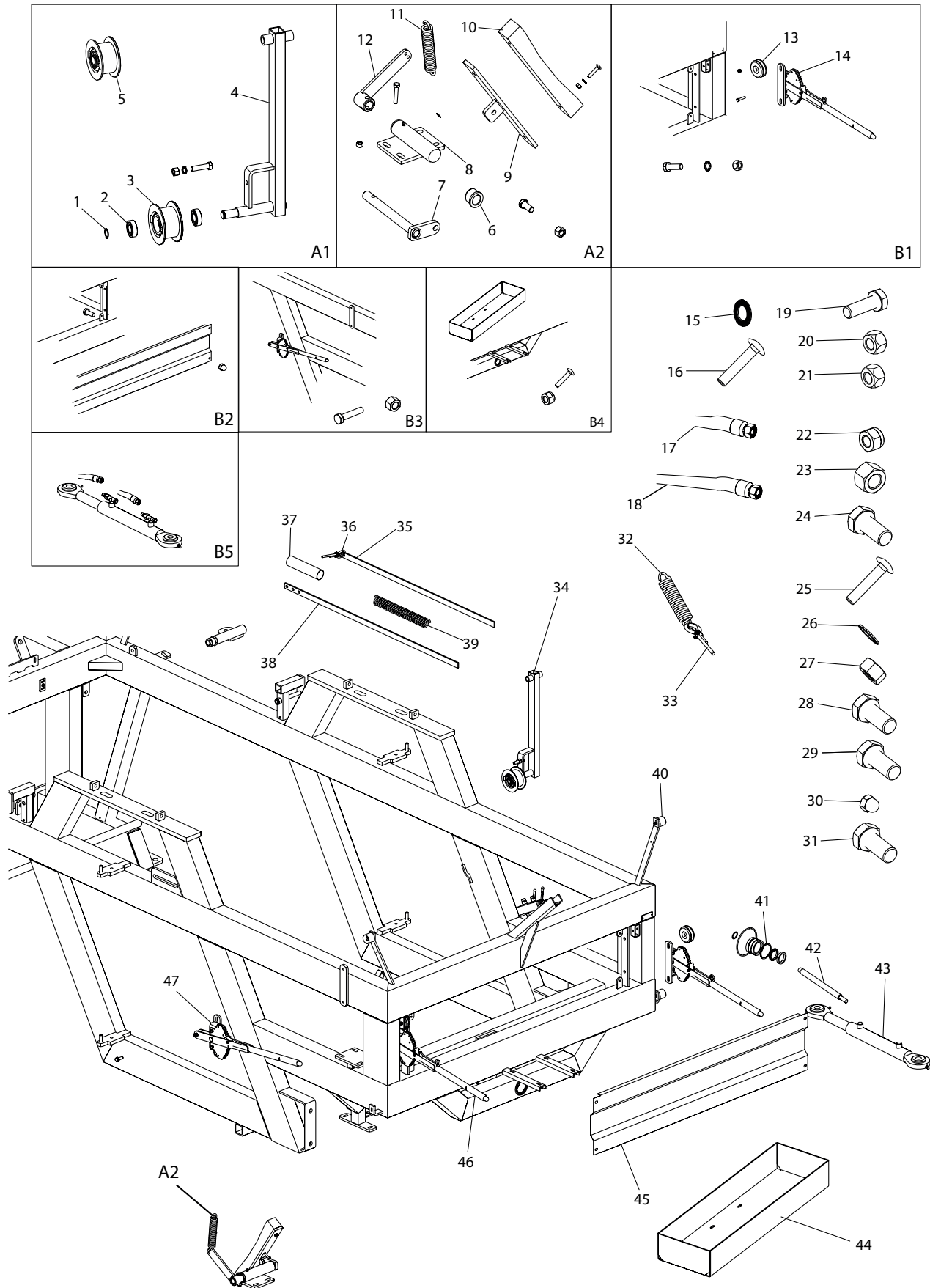

Item no.	Part no.	Qty	Description	Comments
1	700020	1	Retaining ring	A1
2	761105-1	2	Bearing	
3	761106	1	Tension roller	
4	1008375	1	Belt tensioner arm	
5	761106-1	1	Tension rollers with bearings	
6	1009337	2	Bushing	
7	1008355	1	Shaft	
8	1009335	1	Pipe for bushings	
9	902119	1	Brake shoe	
10	902120	1	Brake block	
11	761110	1	Spring	
12	1009275	1	Arm for brake	
13	761015-15	2	Cable roller loose	
14	1009279	1	Belt tensioner lever L	
15	050312	2	M12 Plain washer	A1
16	763720	4	M8 x 25 Carriage bolt	B4
17	1008610	1	Hyd. Hose 400 mm	B5
18	1007515	1	Hyd. Hose 750 mm	B5
19	022212045	1	M12 x 45 Steel set bolt	A1
20	044008	6	M8 Lock nut	B1 & B4
21	040412	1	M12 Steel nut	A1
22	044010	1	M10 Lock nut	A2
23	040408	2	M8 Steel nut	A2
24	021010055	1	M10 x 55 Steel bolt	A2
25	763620	2	M8 x 40 Carriage bolt	A2
26	763908	2	M8 Riplock	A2
27	040416	1	M16 Steel nut	A2
28	022216035	1	M16 x 35 Steel set bolt	A2
29	022208040	2	M8 x 40 Steel set bolt	B3 & B1

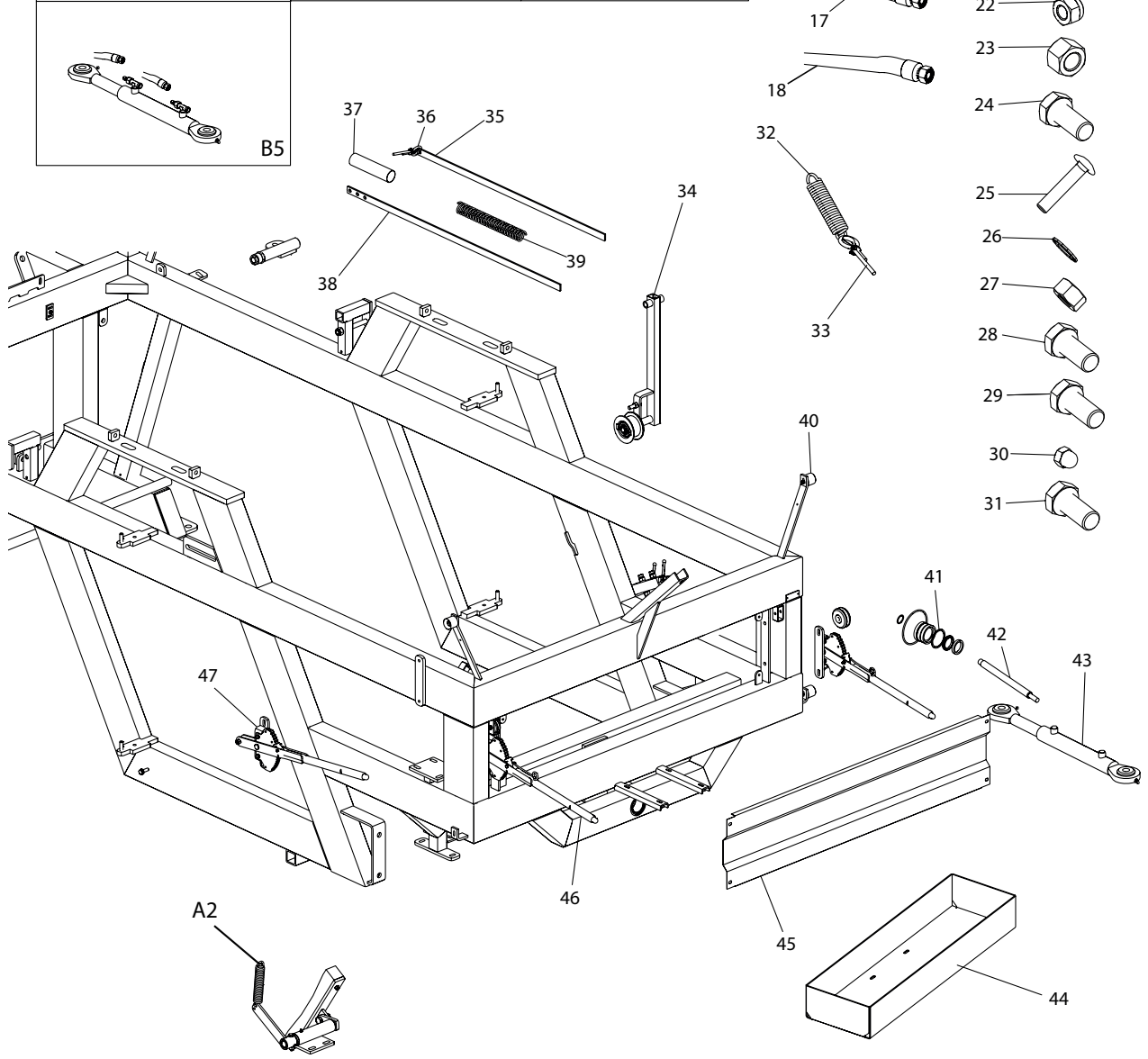
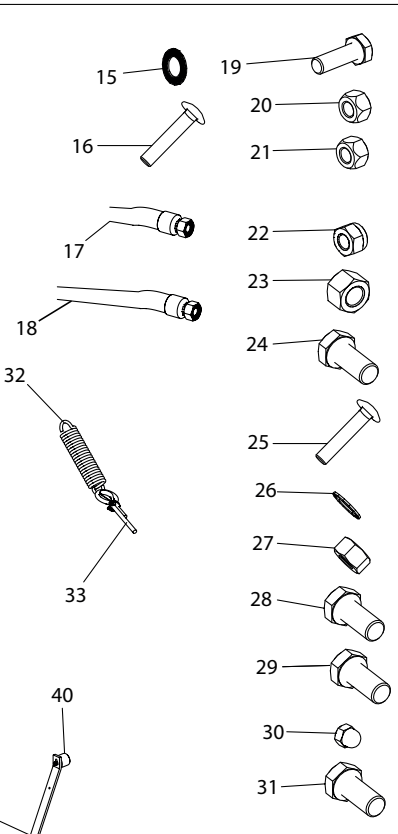
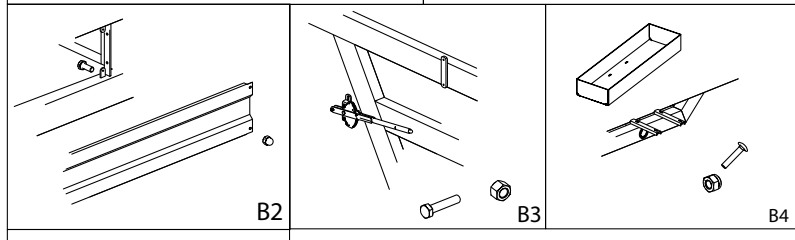
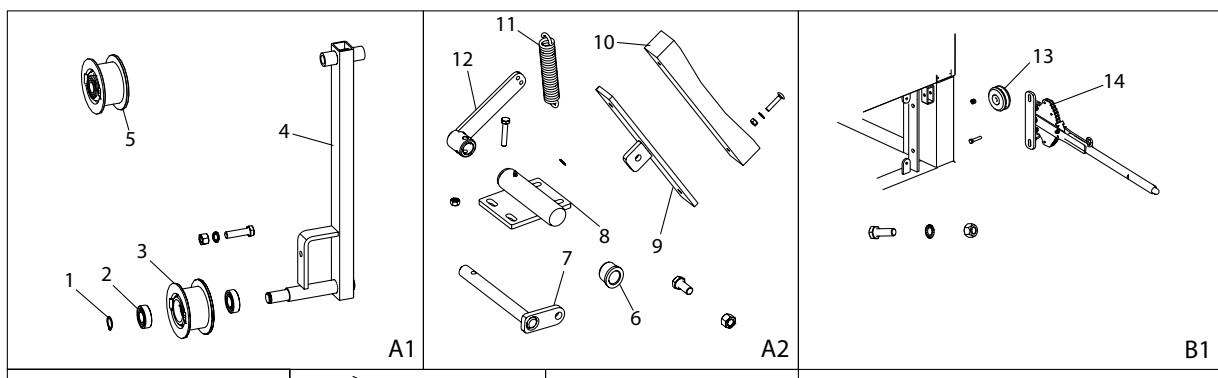

Item no.	Part no.	Qty	Description	Comments
30	763930	4	M8 Cap nut	B2
31	022208020	4	M8 x 20 Steel set bolt	B2
32	1008203	1	Drawbar spring	
33	1007803	1	Cable Ø5 x 3200 mm	
34	1008376	2	Belt tensioner arm	
35	1007754-1	2	Flat steel for drawbar	
36	1007806	2	Cable Ø5 x 1020 mm	
37	1007752	2	Spacer pipe for belt tensioner	
38	1007756-1	2	Rod for belt tensioner	
39	1007750	2	Compression spring	
40	1327102020	8	Door holder Female	
41	1008585-1	1	Gasket set for cylinder	
42	1008585-2	1	Piston rod for cylinder	
43	1008585	1	Front steering cylinder	
44	1009341	1	Toolbox	
45	2006221	1	Front guard	
46	1009277	1	Belt tensioner lever R	
47	761113	1	Coupling lever	

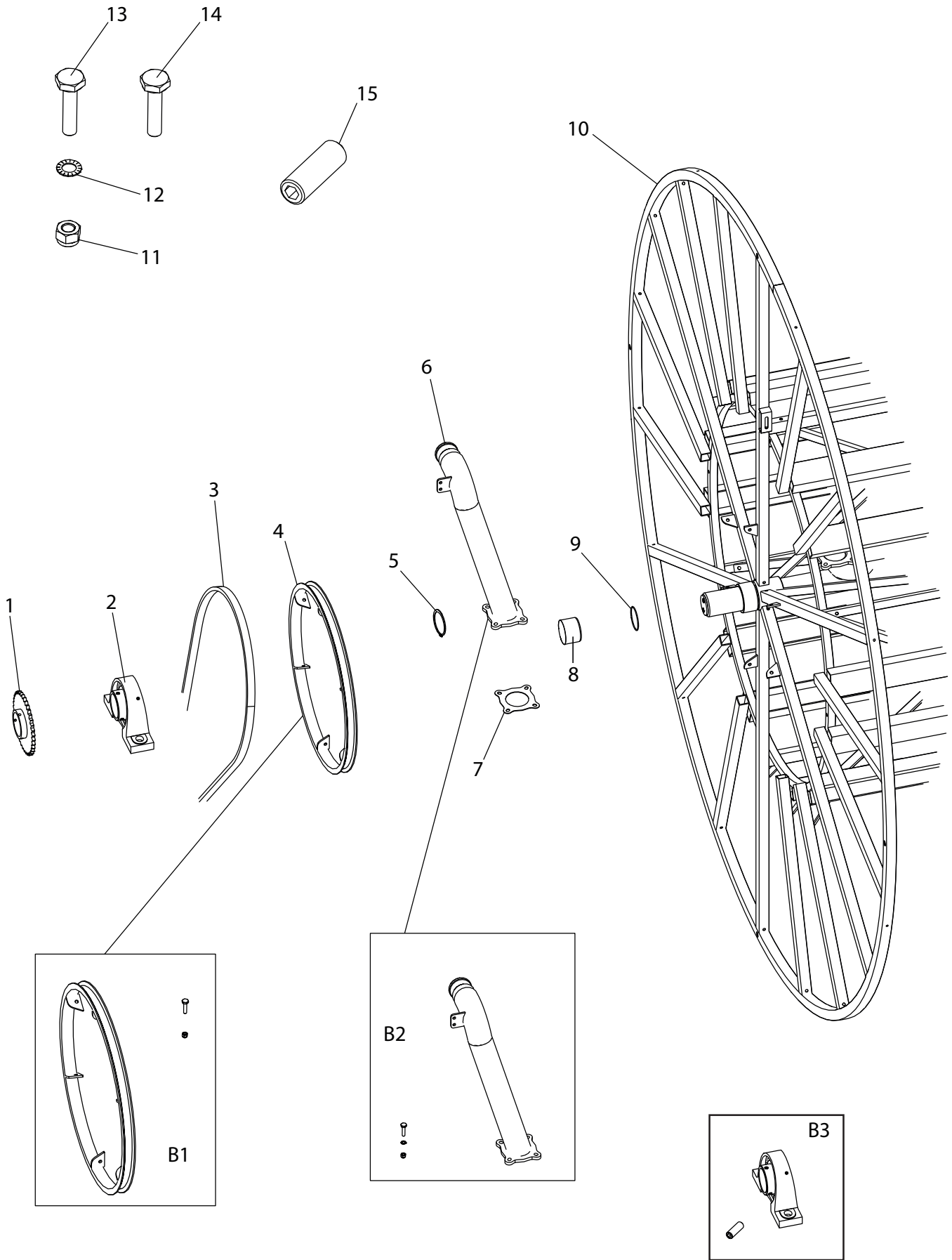

Item no.	Part no.	Qty	Description	Comments
1	1008060	1	Sprocket	
2	1001098	2	Pillow block complete. UCP 218	
3	1761123	2	Belt for drum	
4	1001083	2	Pulley for drum	
5	1007930	1	Retaining ring Ø90 mm ext.	
6	2003334	1	Inlet pipe	
7	631112	1	Flange gasket	
8	1001270	1	Stainless bushing	
9	1007935	1	O-ring under stainless bushing	
10	1008050	1	Hose drum FM4550	
11	044010	18	10 mm Lock nut	B1 & B2
12	763910	12	Riplock 10	B2
13	021010045	6	10 x 45 mm Steel bolt	B2
14	022210025	12	10 x 25 mm Steel bolt	B1
15	0716160161	2	Stop screw with crater	B3

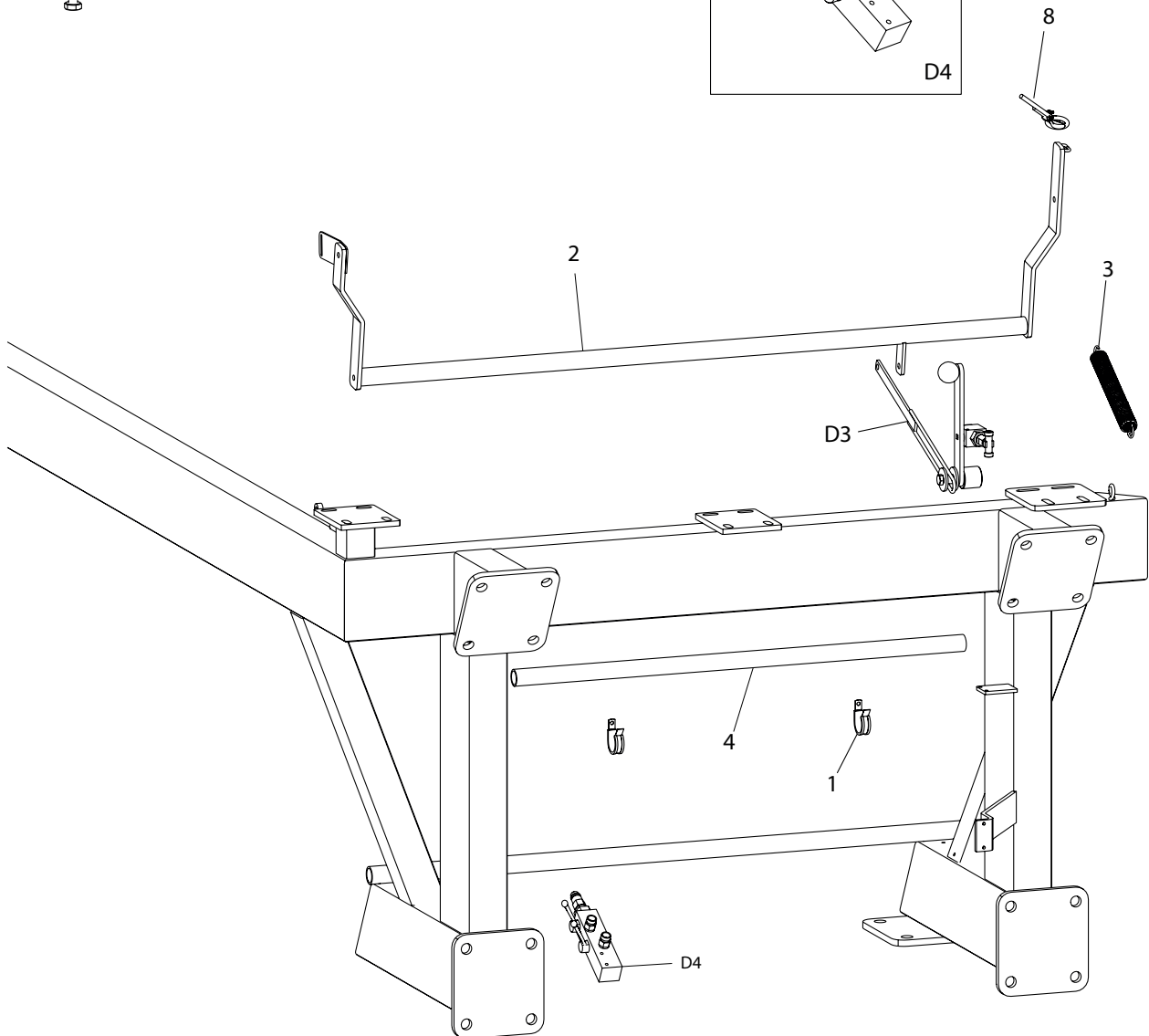
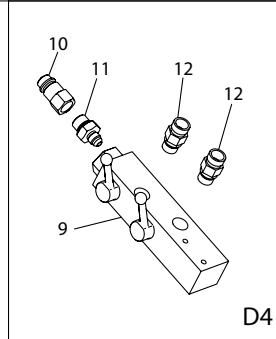
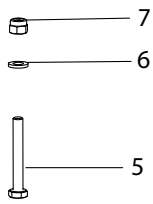
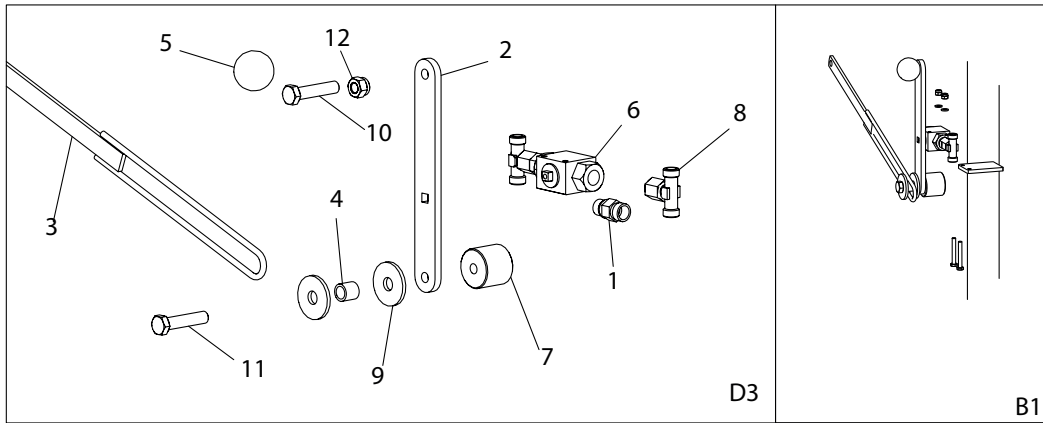

Parts list PÅ D3

Item no.	Part no.	Qty	Description	Comments
1	1007724	2	Nipple	
2	1008335-1	1	Lever for ball valve	
3	1009260	1	Stop bar	
4	109101	1	Spacer	
5	763300	1	Ball lever	
6	1007510	1	Ball valve	
7	1007511	1	Wheel chock	
8	1007518	2	Tee	
9	05401250	2	M12 Round washer	
10	022212035	1	M12 x 35 Steel set bolt	
11	022212055	1	M12 x 55 Steel set bolt	
12	040412	2	M12 Steel nut	

Item no.	Part no.	Qty	Description	Comments
1	1007770	1	Pipe bracket	
2	2006224	1	Miswinder	
3	761274	1	Spring	
4	1009660	1	Plastic pipe for cables	
5	022206045	2	M6 x 45 Steel set bolt	B1
6	051006	2	M6 Plain washer	B1
7	044006	2	M6 Lock nut	B1
8	1007812	1	Cable Ø5 x 7700 mm	
9	1010755	1	2-way ball valve	
10	801710	1	Oil coupling	
11	1007538	1	Nipple Collar nipple	
12	1007724	2	Nipple	

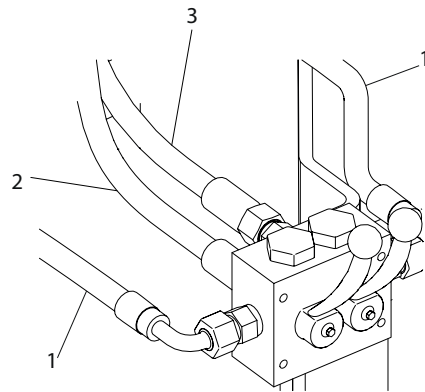
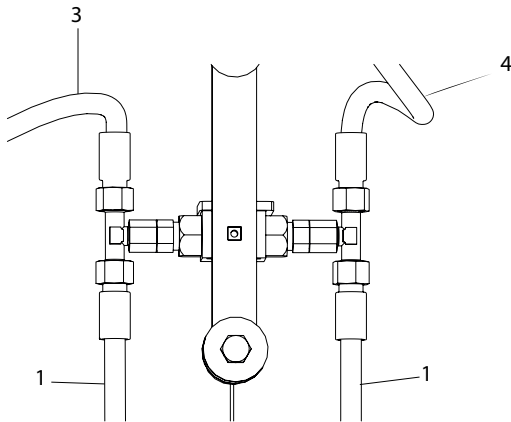
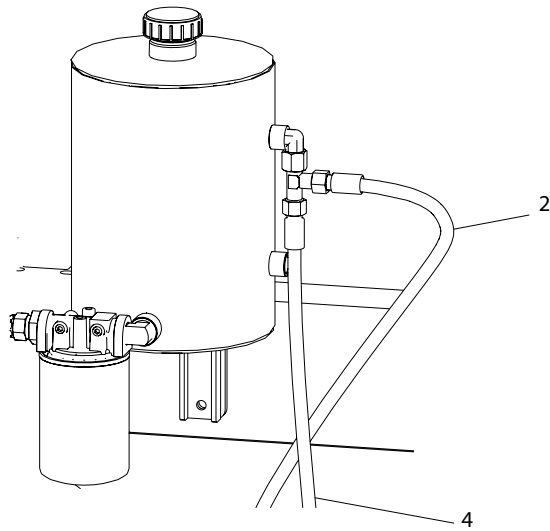
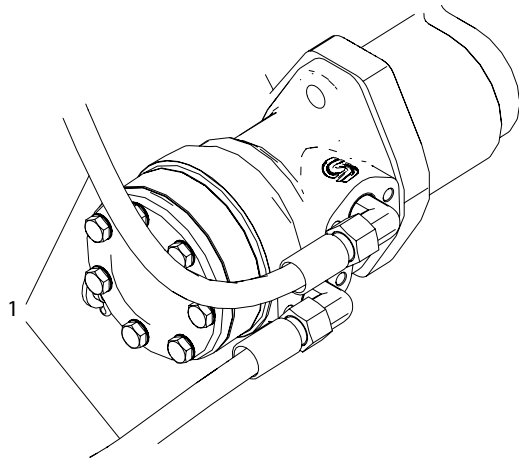
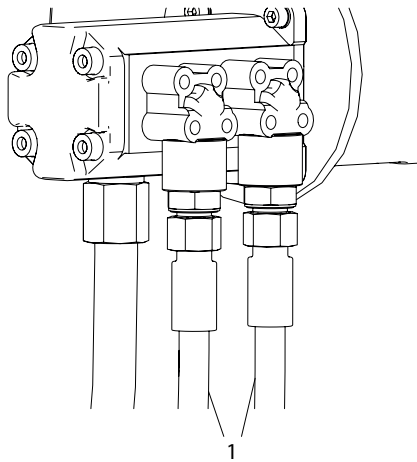

Item no.	Part no.	Qty	Description	Comments
1	1008601	4	Hose 3/8 X 1600 mm	
2	1008609	1	Hose 3/8 X 1200 mm	
3	1008600	1	Hose 3/8 X 1050 mm	
4	1008612	1	Hose 3/8 X 600 mm	

FLADGEAR

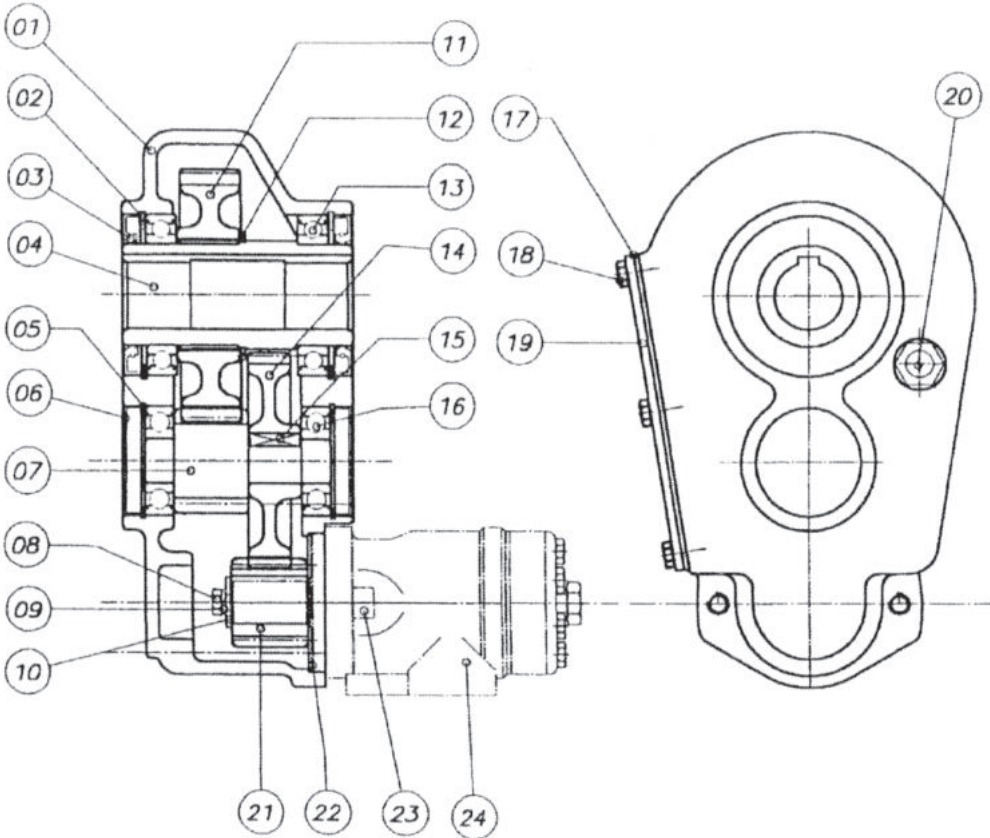

Item no.	Part no.	Qty	Description	Comments
1	1009500	1	Gear Comp	
2	1009504	1	Retaining ring 95 mm	
3	1009505	1	Sealing ring Ø60/95x10	
4	1009506	1	Hollow shaft Ø40	
5	1009507	1	Retaining ring 62 mm	
6	1009508	1	Cover Ø62	
7	1009509	1	Shaft/Gear	
8	1009510	1	Bolt with int. Hex M8 x 20	
9	1009511	1	Washer	
10	1009512	1	Spring washer	
11	1009513	1	Gear	
12	1009514	1	Retaining ring 65 mm	
13	1009515	1	Bearing	
14	1009516	1	Gear	
15	1009517	1	Spring	8 x 7 x 30
16	1009518	1	Bearing	6305
17	1009519	1	Flange gasket	
18	1009520	1	M8 x 16 mm	
19	1009521	1	Cover	
20	1009522	1	Sight glass	1/2
21	1009523	1	Gear	
22	1009524	1	Gasket	
23	1009529	1	Int. hex M12 x 35	
24	1007440	1	Oil motor	

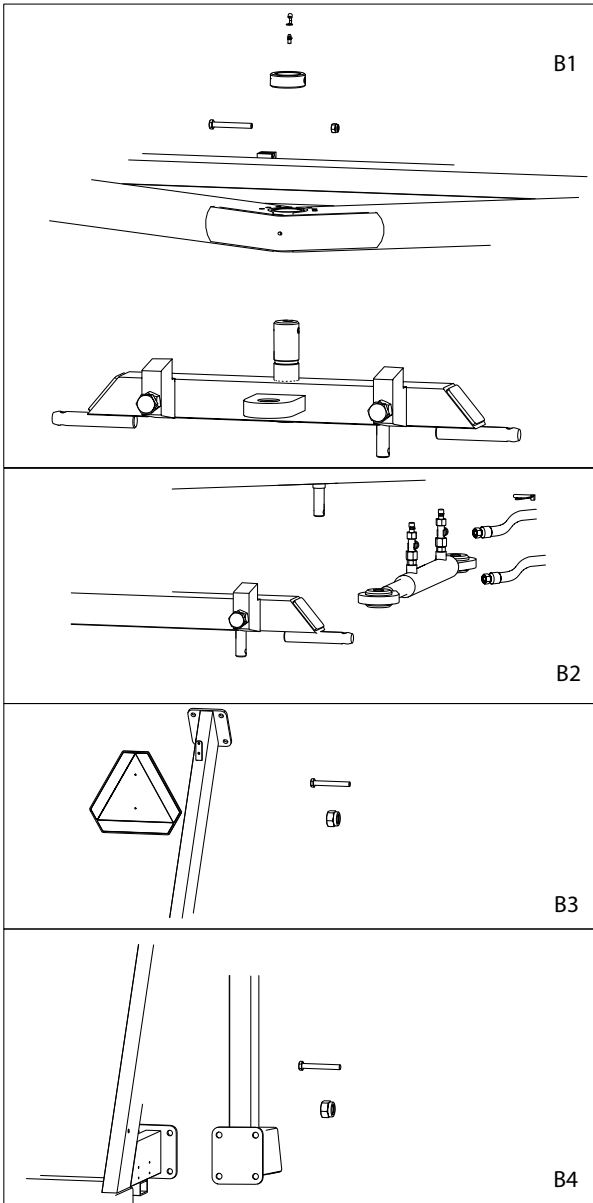

- 9 —
- 10 —
- 11 —
- 12 —
- 13 —
- 14 —
- 15 —
- 16 —
- 17 —
- 18 —

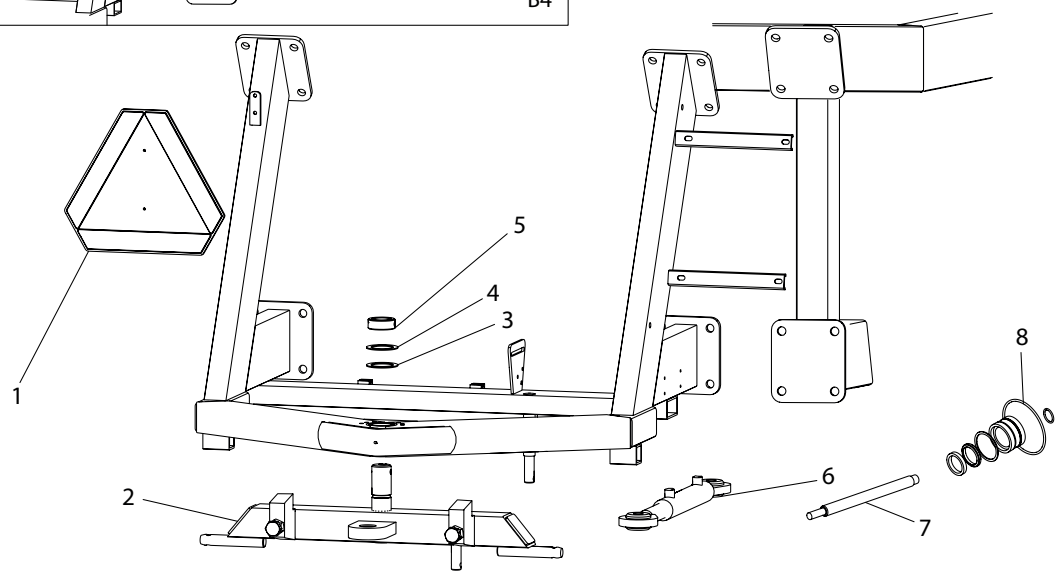

Item no.	Part no.	Qty	Description	Comments
1	1008966	1	Warning triangle	
2	1008250	1	Rear drawbar comp	
3	895630	7	Support ring	
4	1008198	7	Spacer washer	
5	1008195	1	Stop ring	
6	1008585	1	Cylinder for forced steering	
7	1008585-2	1	Piston rod for cylinder	
8	1008585-1	1	Gasket set for cylinder	
9	022210080	1	M10 x 80 Steel set bolt	B1
10	761286-2	1	Lubrication cap	B1
11	761286	1	Lubrication nipple	B1
12	044010	1	M10 Lock nut	B1
13	763642	1	Tractor split pin	B2
14	022216045	16	M16 x 45 Steel set bolt	B4
15	044008	2	M8 Lock nut	B3
16	022208016	2	M8 x 16 Steel set bolt	B3
17	040416	16	M16 Lock nut	B4
18	1008614	2	Hyd. Hose for forced steering	B2 the same

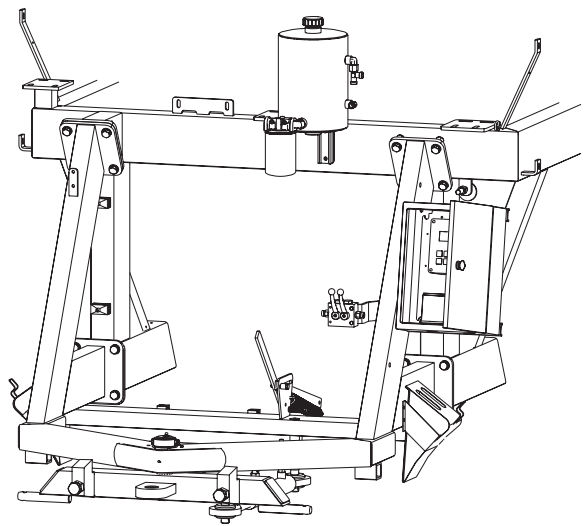

- 19
- 18
- 17
- 16
- 15
- 14
- 13
- 20
- 21
- 22
- 23
- 24

- 10
- 12
- 5
- 8
- 9
- 4
- 11
- 7
- 6
- 3
- 2

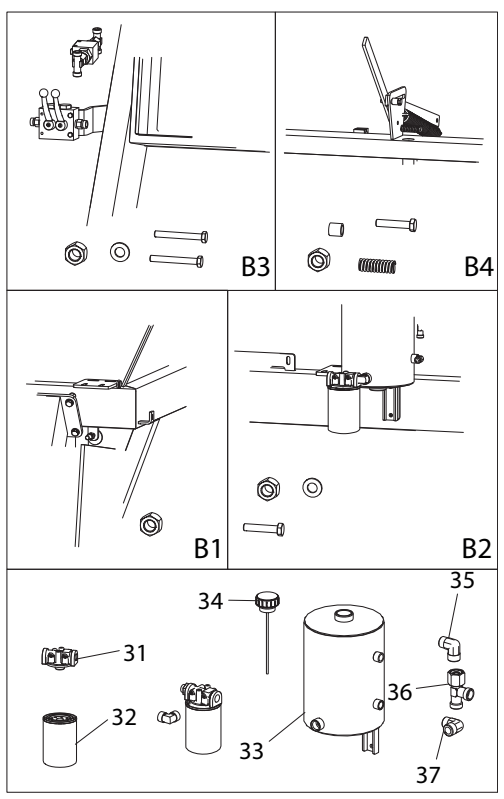

- 29
- 30
- 25
- 26
- 27
- 28
- 31
- 32
- 33
- 34
- 35
- 36
- 37

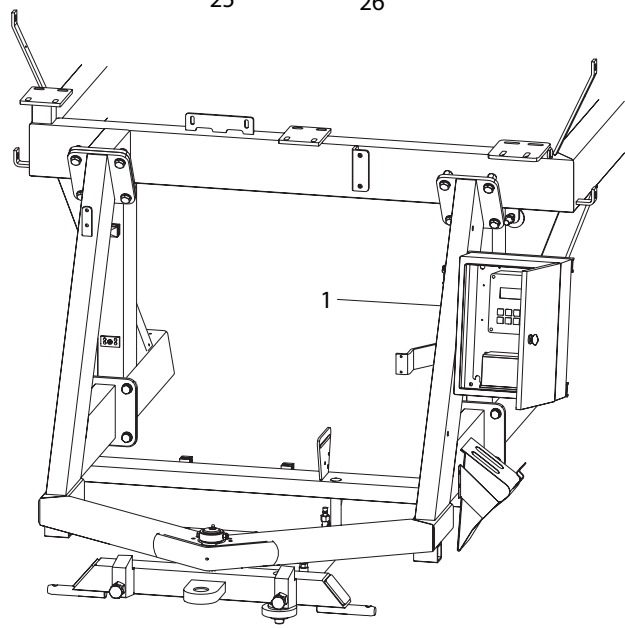

Item no.	Part no.	Qty	Description	Comments
1	1009150	1	Rear drawbar	
2	1011011	1	Drawbar spring	
3	2006359-1	1	Release arm	
4	68006	1	Rubber grip	
5	1009250	1	Lever for decoupling	
6	1005805	2	Holder for stop wedge	
7	1005800	2	Stop wedge	
8	1007540	2	Angle Cyl	
9	1010750	1	Ball valve for Dual pump	
10	1009350	2	Stop bolt for miswinding bar	
11	1007514	2	Hose carrier	
12	1007510	1	Ball valve for decoupling	
13	051006	4	M6 Plain washer	B3
14	022206045	2	M6 x 45 Steel set bolt	B3
15	022210030	2	M10 x 30 Steel set bolt	B2
16	1009252	1	Compression spring for coupling	
17	022210080	1	M10 x 80 Steel set bolt	B4
18	022206055	2	M6 x 55 Steel set bolt	B3
19	109101	1	Spacer for switch	
20	1008198	2	Spacer washer for Rear drawbar	
21	763910	4	M10 Riplock	B2
22	044006	4	M6 Lock nut	B3
23	040410	3	M10 Steel nut	B4 & B2
24	040416	2	M16 Steel nut	B1
25	1007590	1	Plate for battery	
26	1005521	1	Battery	
27	1007578	1	Electric box	
28	1007584	1	Lock for box	
29	1007549-1	1	Exchanger Prog Rain	
30	1007549-7	1	Prog. Rain.	
31	1007484	1	Filter housing	
32	1007482	1	Hydraulic filter	
33	1007490	1	Tank	
34	1007500	1	Tank Cover	
35	1007536	1	Angle	
36	1007526	1	Nipple	
37	1007540	1	Angle	

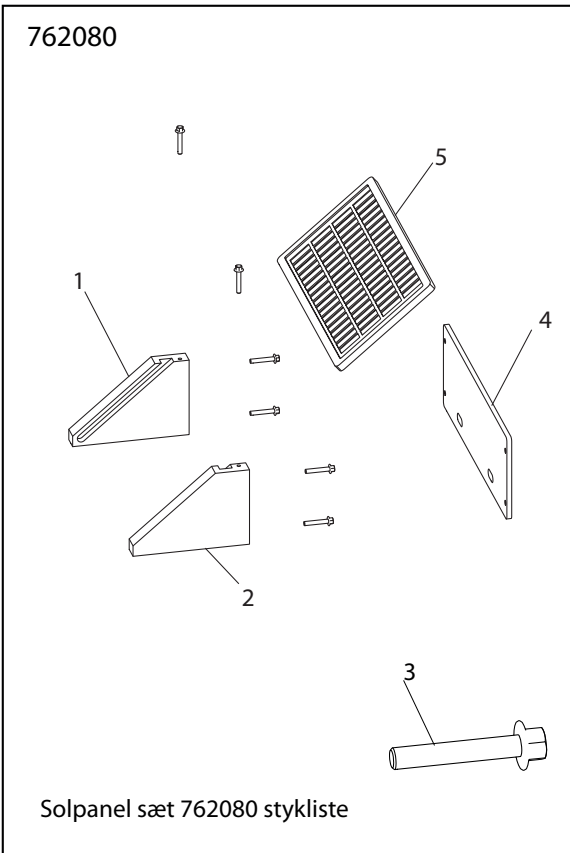
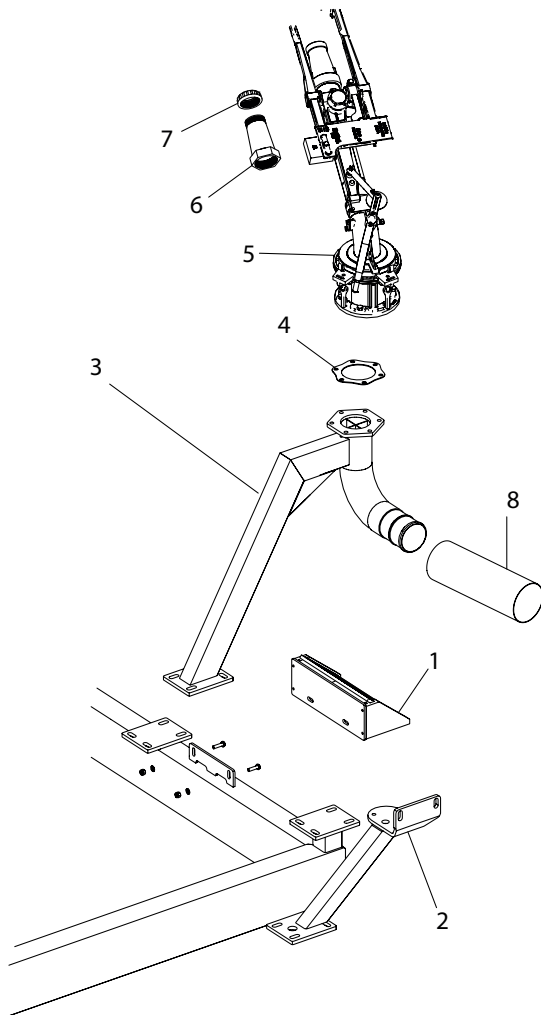
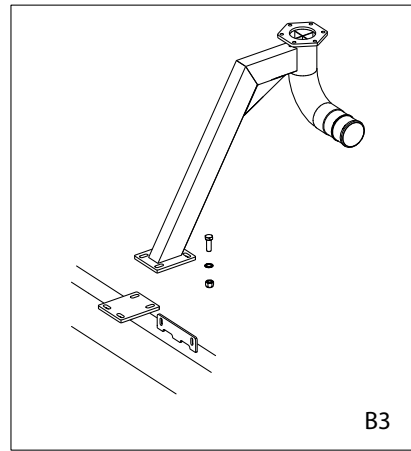
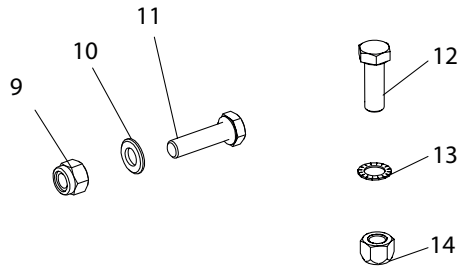
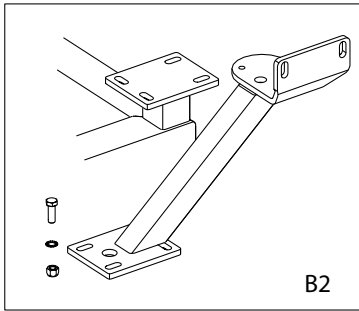
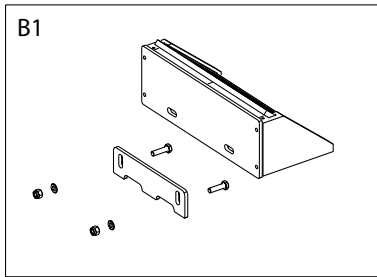

Item no.	Part no.	Qty	Description	Comments
1	762080	1	Solar panel set	
2	1009120	1	Suspension for turbine	
3	1007655	1	Gun pipe with 90° bend	
4	761614	1	Flange gasket Gun	
5	770145		Gun	
6	7712781		150TR Plastic body	
7	7712467		150TR Plastic cap	
8	16050210	1	Soft hose no. per running metre.	530 mm
9	044008	2	M8 Lock nut	B1
10	050308	2	M8 Plain washer	B1
11	021008030	2	M8 x 30 Steel bolt	B1
12	022212035	8	M12 x 35 Steel bolt	B2 & B3
13	763912	16	Riplock M12	B2 & B3
14	040412	8	M12 Steel nut	B2 & B3

Parts list 762080 Solar panel

Item no.	Part no.	Qty	Description	Comments
1	2001259	1	Holder for solar cell L	
2	2001260	1	Holder for solar cell R	
3	510555	1	Ø4.8 x 32 SuperTEKS 6	
4	2002533	1	Galvanized plate for solar panel	
5	1005523	1	Solar panel for constant	

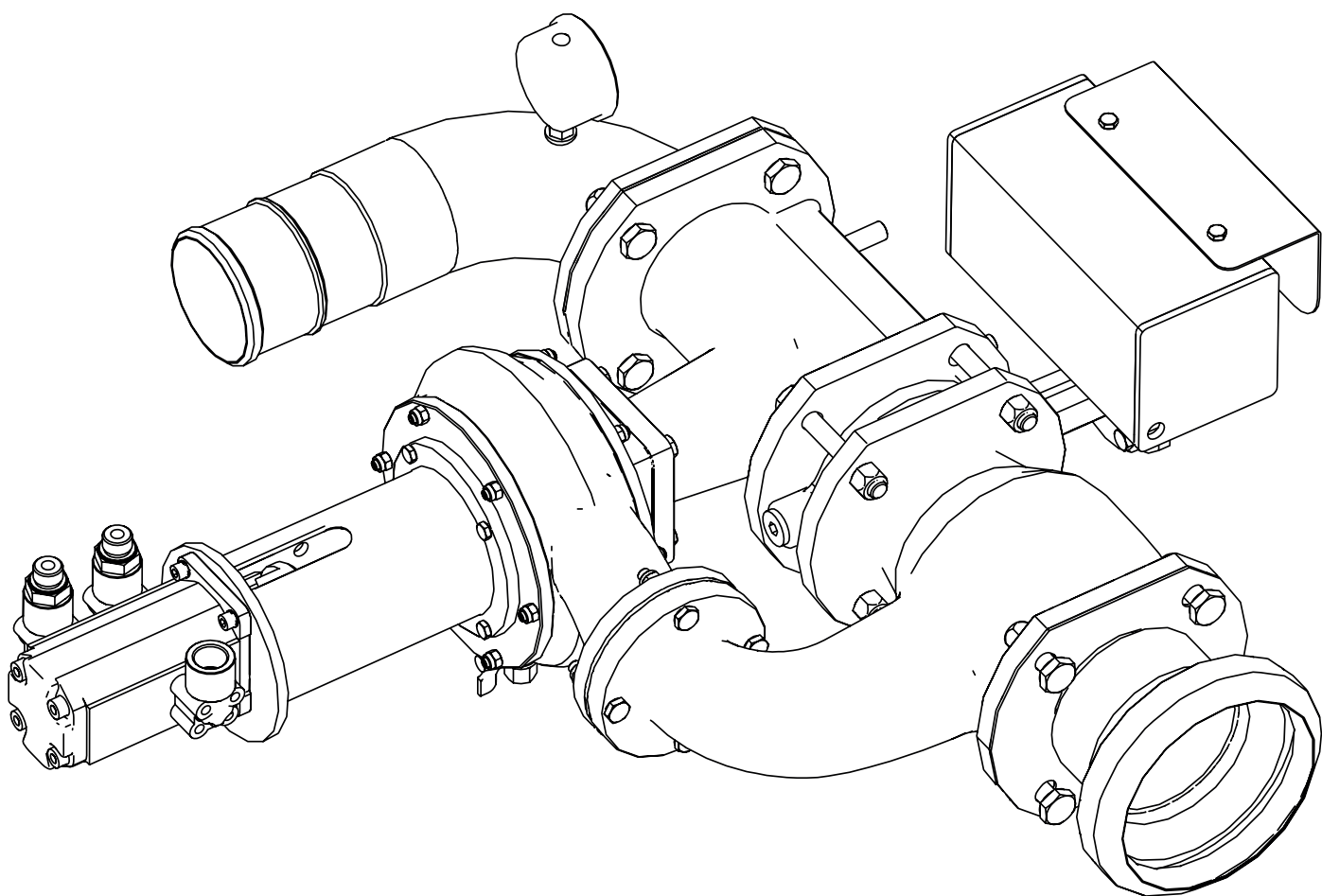

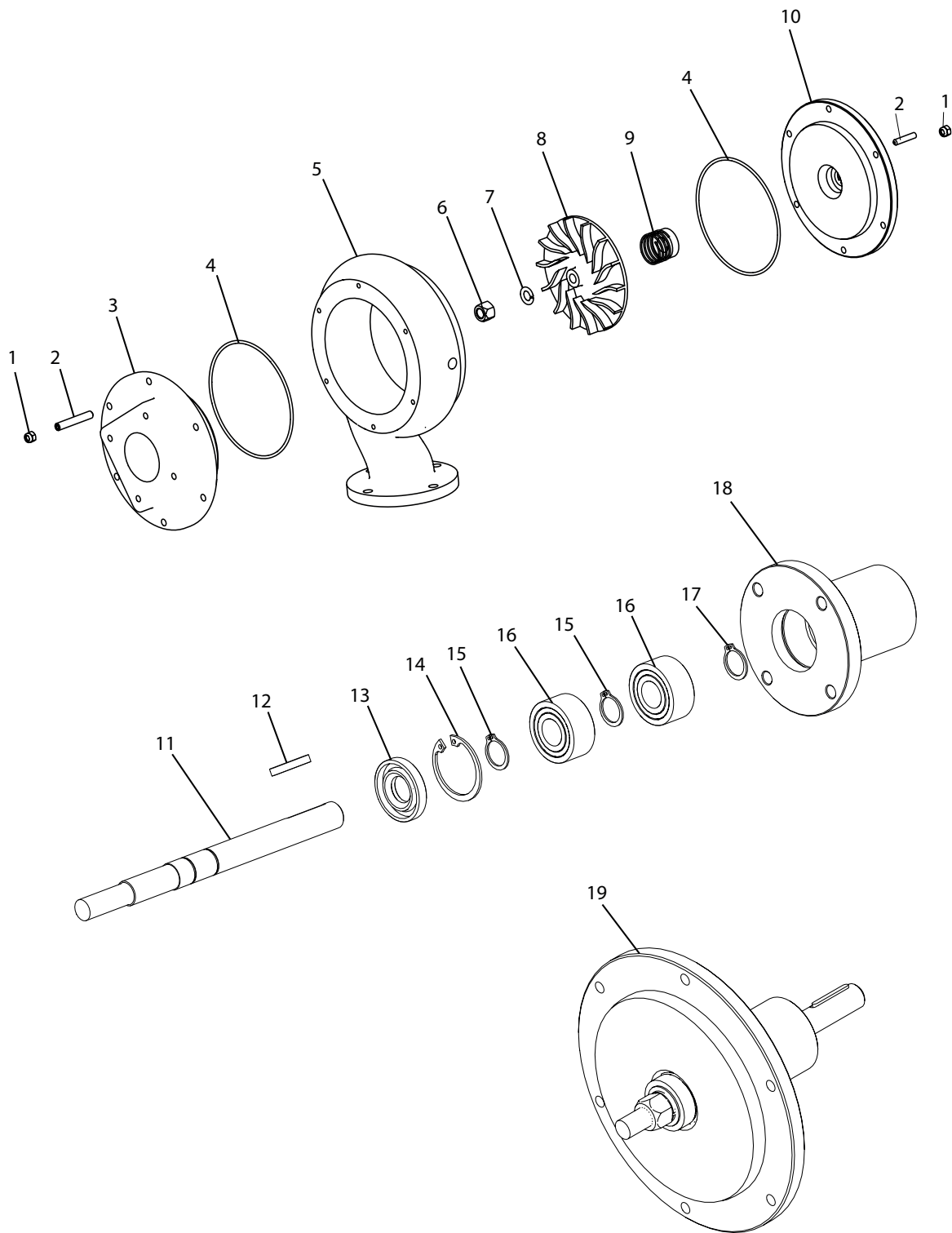

Item no.	Part no.	Qty	Description	Comments
1	095906	16	M6 Lock nut	
2	096506029	16	M6 x 29 Support bolt Pinol	
3	13000086	1	Upper flange turbine for top pipe	
4	195211	2	O-ring cover	
5	195001	1	Turbine housing	
6	096012	1	M12 Nut	
7	096112	1	M12 Spring washer	
8	195031	1	Impeller	
9	P195201	1	Shaft seal for turbine	
10	195018	1	Packing block cover 20/50	
11	195036	1	Shaft	
12	195255	1	Spring	4 x 4 29
13	195050	1	Sealing ring	
14	701035	1	Retaining ring Int.	
15	700015	2	Retaining ring Ext.	
16	195220	2	Front bearing	
17	517715	1	Clamping ring	
18	195013	1	Bearing housing	
19	195500	1	Turbine cover complete	
20	195000V	1	Complete turbine.	

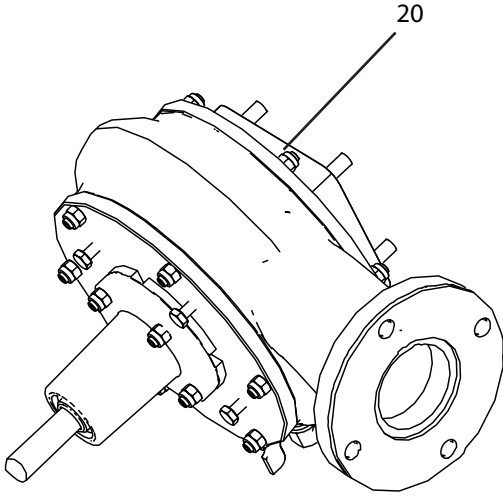

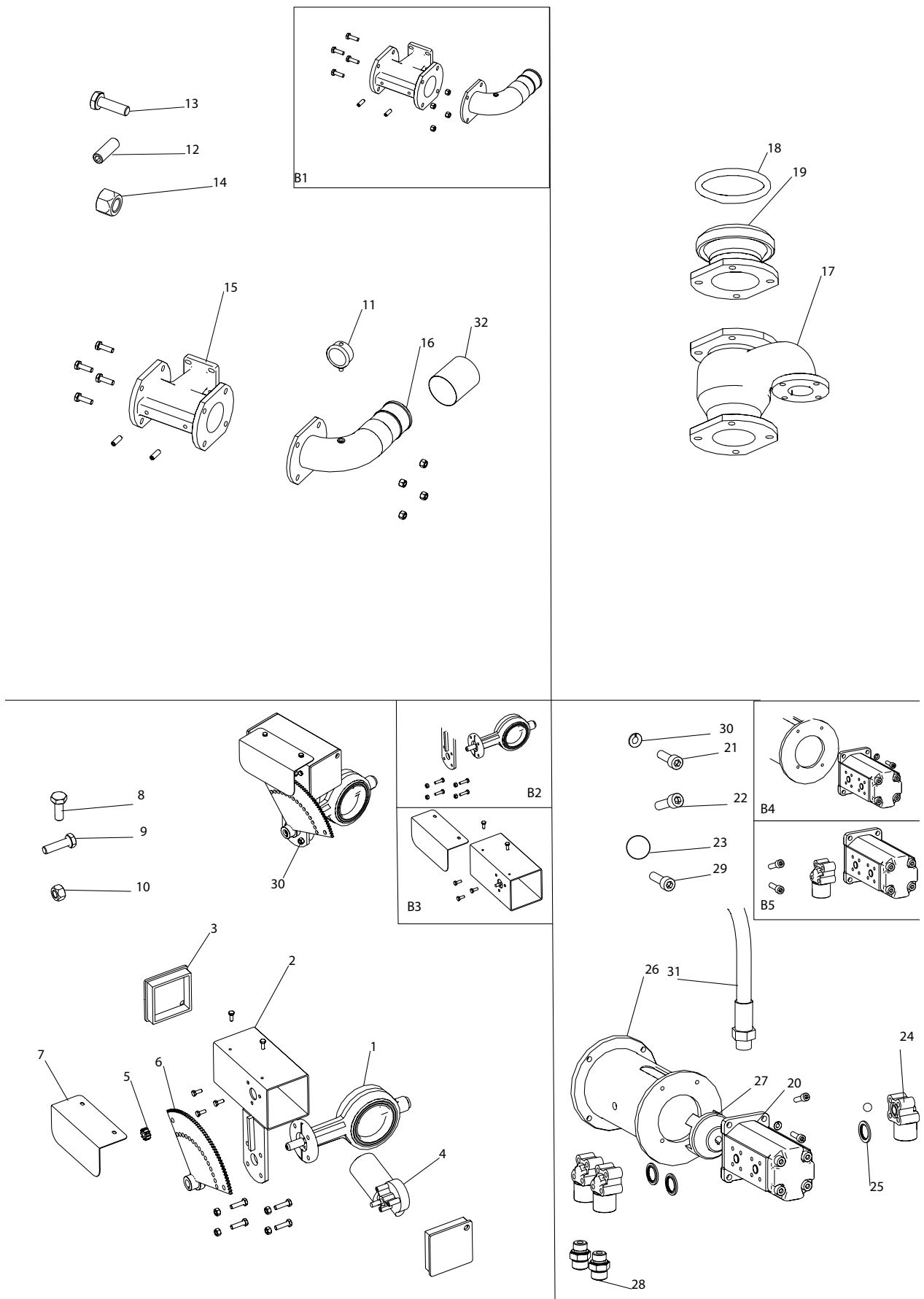

Item no.	Part no.	Qty	Description	Comments
1	1007250	1	Butterfly valve	
2	1007171	1	Motor housing for motor valve	
3	1007175	2	End plug for motor valve	
4	1007180	1	Motor for valve	
5	1007190	1	Gear for electric motor	
6	1007195	1	Gear for valve	
7	1007185	1	Guard for motor valve	
8	022206016	5	M6 x 16 Steel set bolt	B3
9	022208030	4	M8 x 30 Steel set bolt	B2
10	040408	4	M8 Steel nut	B2
11	1001163	1	Manometer glycerine	
12	763764	2	M12 x 50 Int. hex	B1
13	021012040	4	M12 x 40 Int. hex	B1
14	040412	4	M12 Steel nut	B1
15	33000227	1	Outlet pipe for turbine	
16	1009324	1	Flange with bend	
17	33000226	1	Base pipe for turbine	
18	14050043	1	Rubber ring	
19	1009328	1	Flange with HK cup	
20	1007415	1	Dual pump	
21	030506040	6	M6 x 40 Int. hex	B5
22	030506030	6	M6 x 30 Int. hex	B5
23	2.62 x 15.08	3	O-ring	
24	1007420	3	Flange for oil pump	
25	552024	3	Sealing ring 1/2	
26	1007110	1	Flange for pump	
27	1007450	1	Coupling part	
28	1007726	2	Nipple 1/2	
29	030506020	4	M6 x 20 Int. hex	B4
30	056206	4	M6 Spring washer	B4
31	1008605	1	Hydraulic hose 1/2	
32	16050210	1	Soft hose no. per running metre.	530 mm
33	1007230	1	Comp Motor valve	

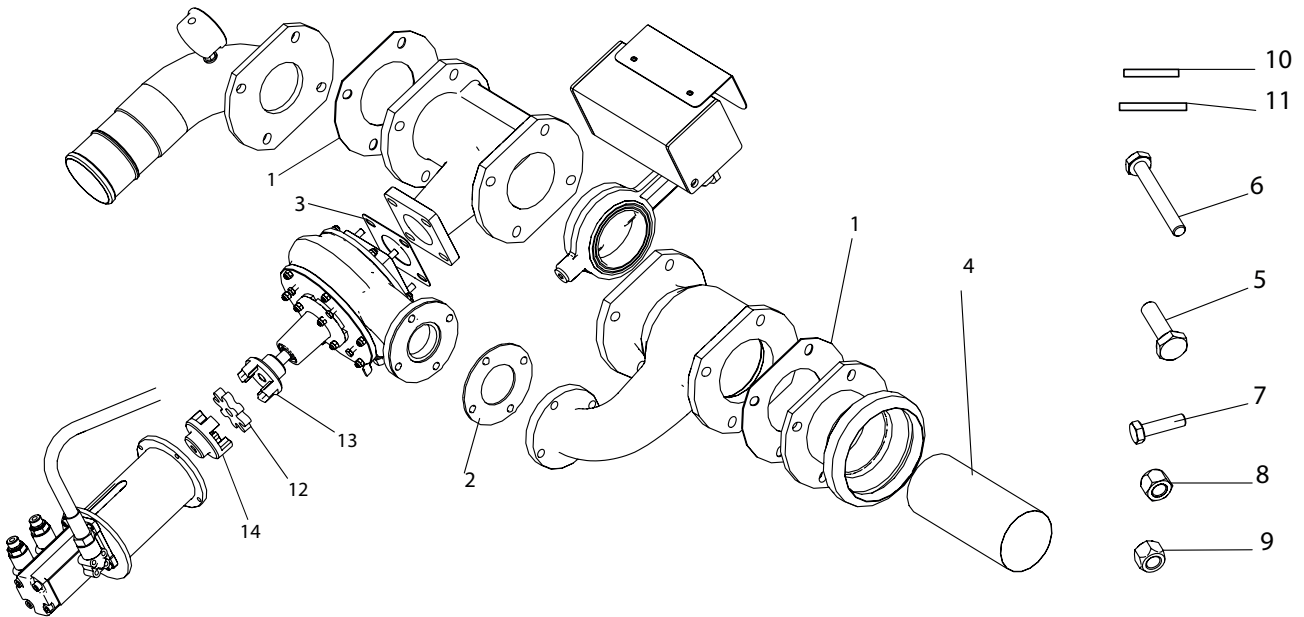
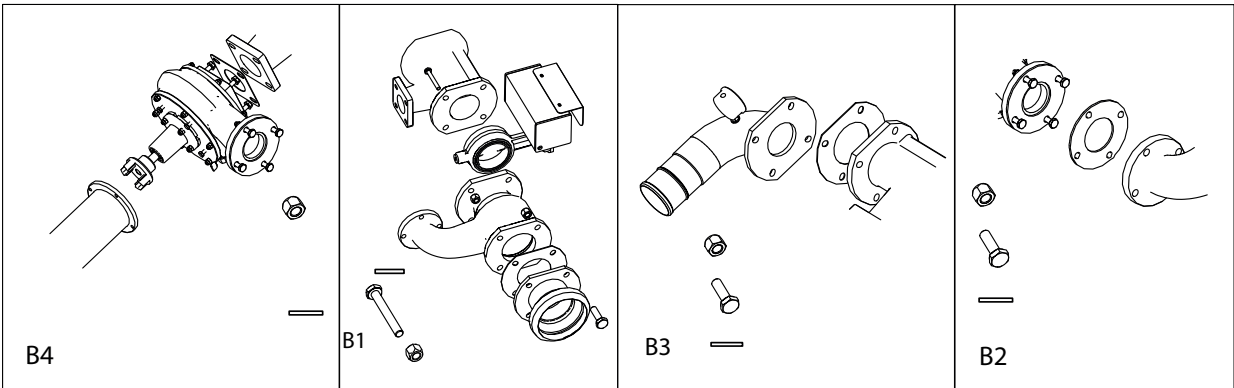

Item no.	Part no.	Qty	Description	Comments
1	631109	2	Flange gasket	
2	522085	1	Flange gasket	
3	631955	1	Flange gasket	
4	1005753	1	Filter	
5	021008045	4	M8 x 45 Steel bolt	B2
6	021010095	4	M10 x 95 Steel bolt	B1
7	022210040	8	M10 x 40 Steel set bolt	B1 & B3
8	040408	12	M8 Steel nut	B2 & B4
9	040410	12	M10 Steel nut	B3 & B1
10	763908	16	M8 Riplock	B2 & B4
11	763910	24	M10 Riplock	B3 & B1
12	1007470	1	Rubber for coupling	
13	1007450	1	Claw coupling Turbine	
14	1007460	1	Claw coupling Oil motor	

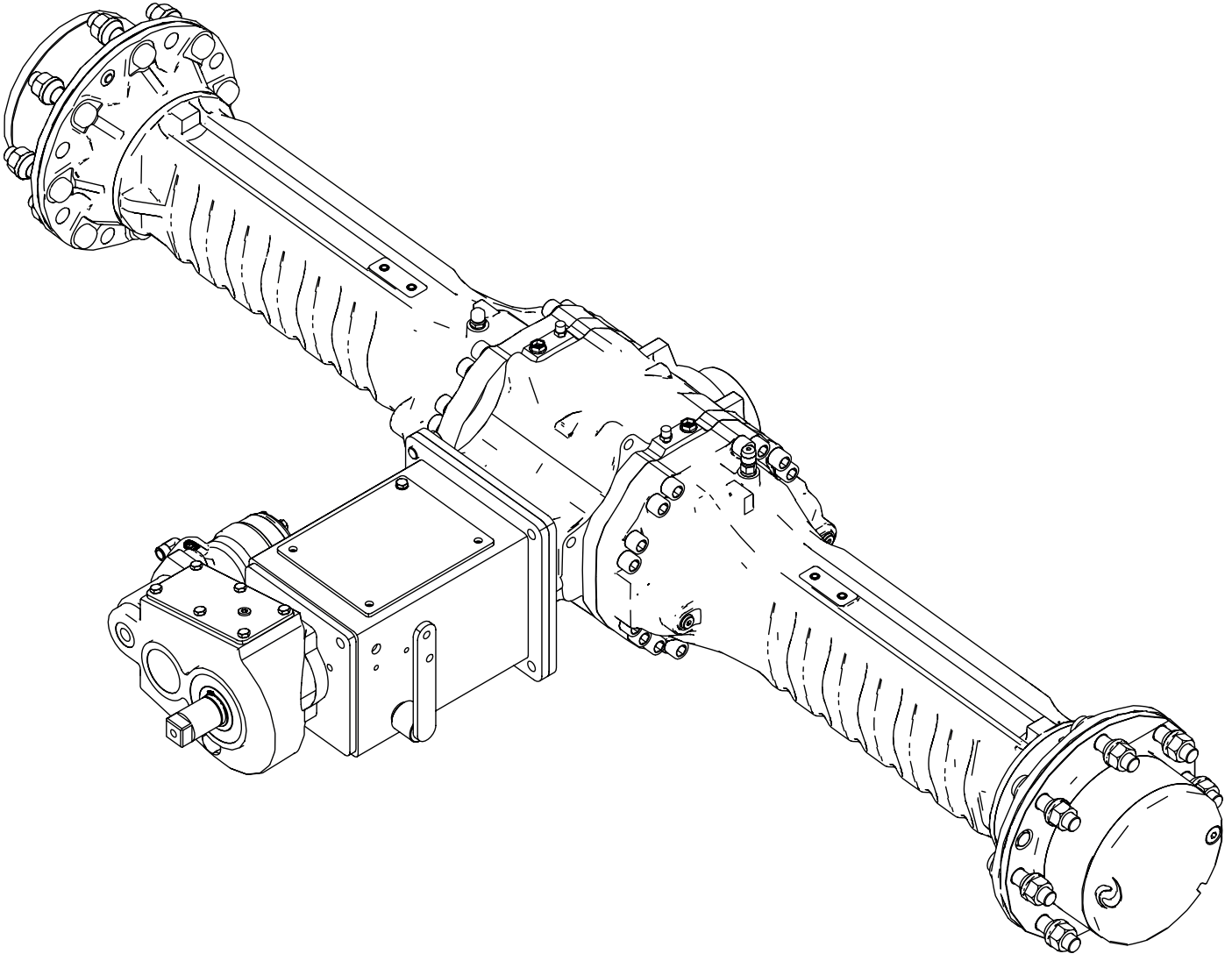

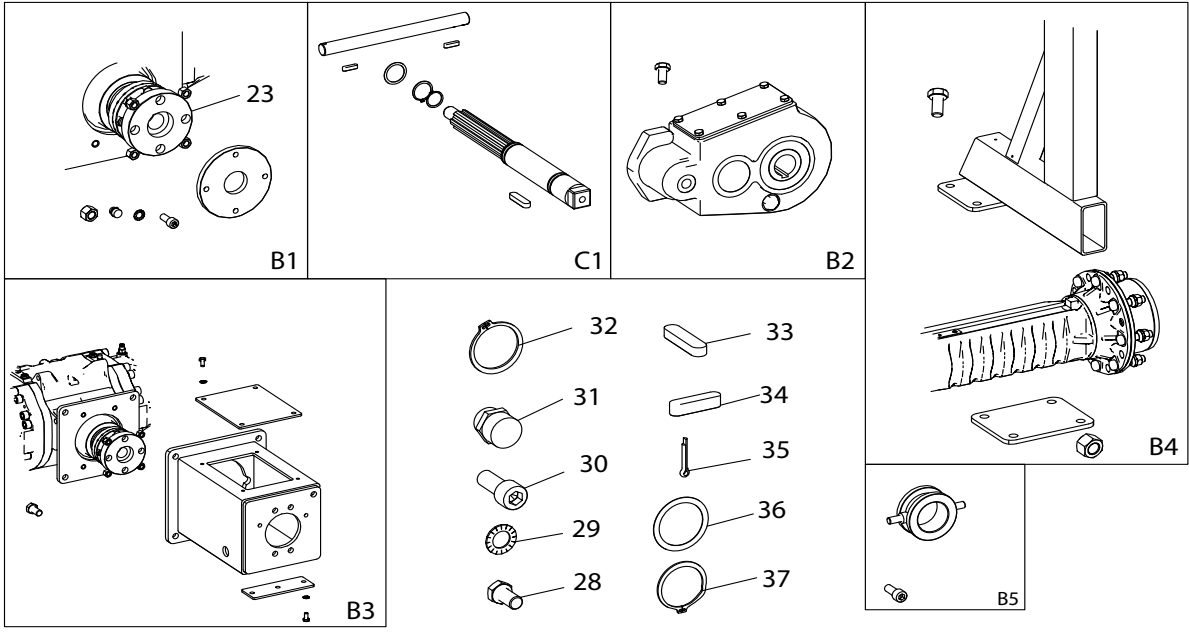

- 32
- 31
- 30
- 29
- 28
- 27
- 26
- 25
- 24
- 33
- 34
- 35
- 36
- 37
- 38
- 39

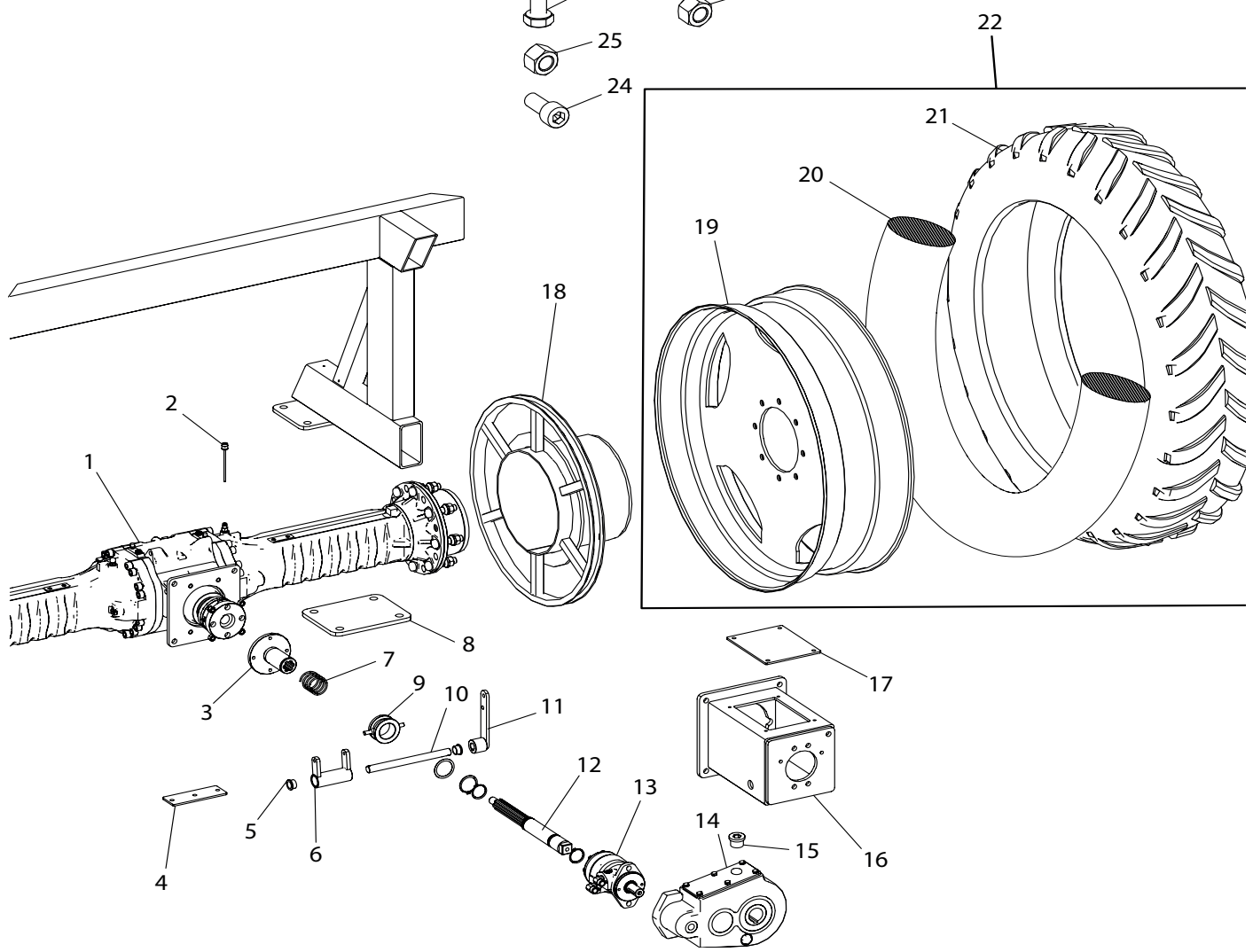

Item no.	Part no.	Qty	Description	Comments
1	1009492	1	Rear axle assembly	
2	2002813	1	Dipstick	
3	1009220	1	Coupling hub	
4	1009207	1	Base cover	
5	1009203	2	Bushing	
6	1009240	1	Shift fork	
7	1009227	1	Compression spring	
8	2002039	2	Clamping plate for rear axle assembly	
9	1009225	1	Shift sleeve	
10	1009235	1	Shaft	
11	1009245	1	Shift arm	
12	1009230	1	Shaft for coupling	
13	1007440	1	Oil motor	
14	1009500	1	Flat gear	
15	1007728-5	1	Plug for flat gear	
16	2002057	1	Coupling housing	
17	1009205	1	Cover	
18	1009274	2	Pulley	
19	1008765	2	Rim	
20	1008715	2	Hose	
21	1008710	2	Rear tyre	
22	2007429	1	Comp wheel	
23	1009215	1	Hub for magnet	
24	763765	2	M10 x 20 Unbraco	B5
25	044020	8	M20 Lock nut	B4
26	021020220	8	M20 x 220 Steel bolt	B4
27	763910	4	M10 Riplock	B1
28	022208016	12	M8 x 16 Steel set bolt	B3 & B2
29	763908	6	M8 Riplock	B3
30	763770	4	M10 x 22 Unbraco	B1
31	1007571	4	Magnet	B1
32	700040	2	Retaining ring	C1
33	641625	2	Spring	C1
34	641850	1	Spring	C1
35	761010	1	Split pin	
36	1009222	1	Shim ring	C1
37	700048	1	Retaining ring	C1
38	022216030	4	M16 x 30 Steel set bolt	B3
39	044010	4	M10 Lock nut	B1

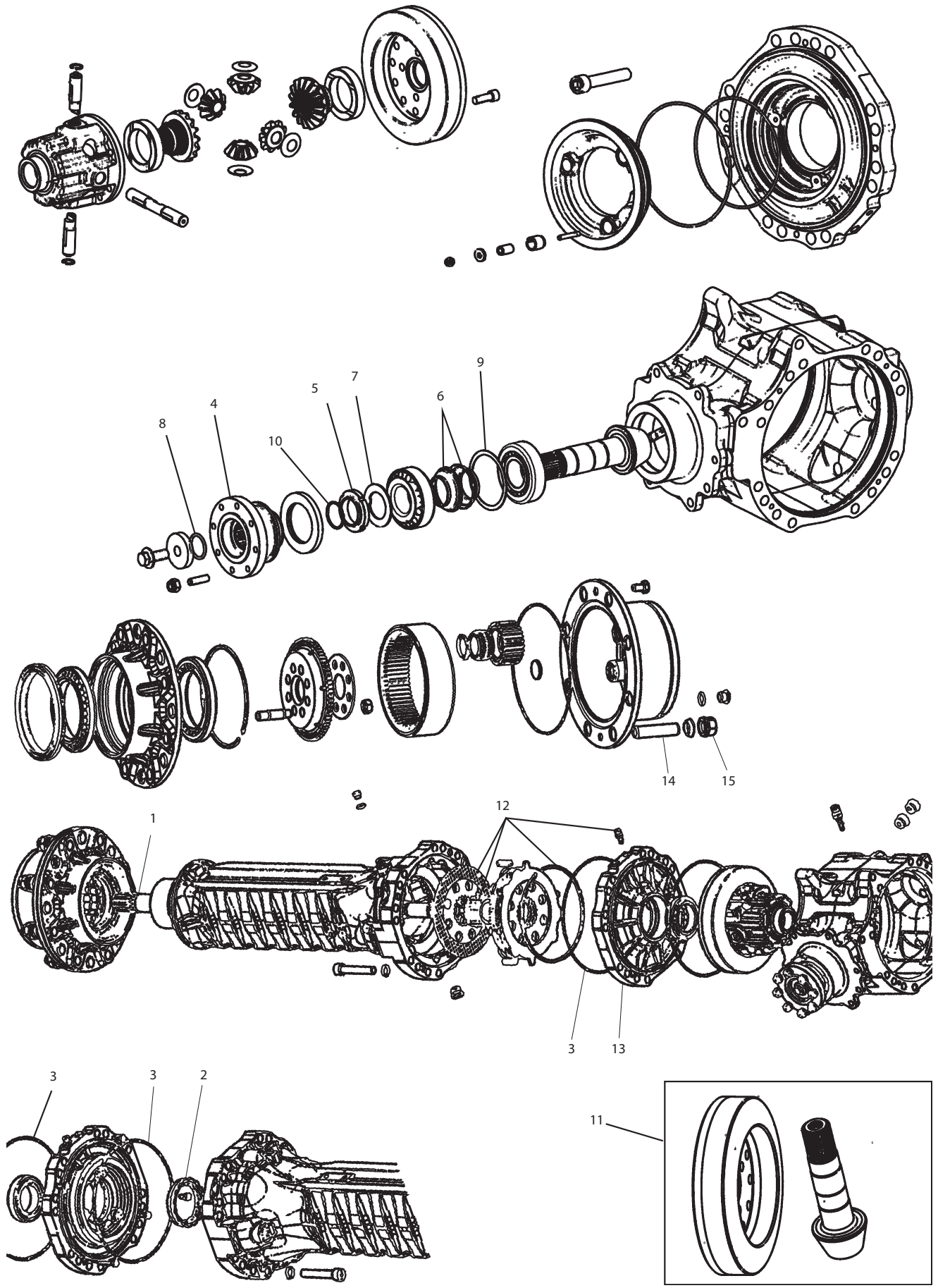

Item no.	Part no.	Qty	Description	Comments
1	1009570	2	Shaft FM4550	
2	1009571	2	Ring nut	
3	1009572	4	O-ring 3.53 x 240.89	
4	1009573	1	Cardan flange	
5	1009574	1	Ring nut M40	
6	1009575	2	Spring cup	
7	1009576	1	Lock washer	
8	1009577	1	O-ring 3.53 x 29.75	
9	1009578	1	Shim washer Ø76	
10	1009579	1	Retaining ring without ears	
11	1009580	1	Crown/Pinion	
12	1009581	2	Brake Repair Set	
13	1009582	2	Pressure flange for brake	
14	1009455-6	18	Hub bolt M22 x 50	
15	1009456-4	18	Hub nut	

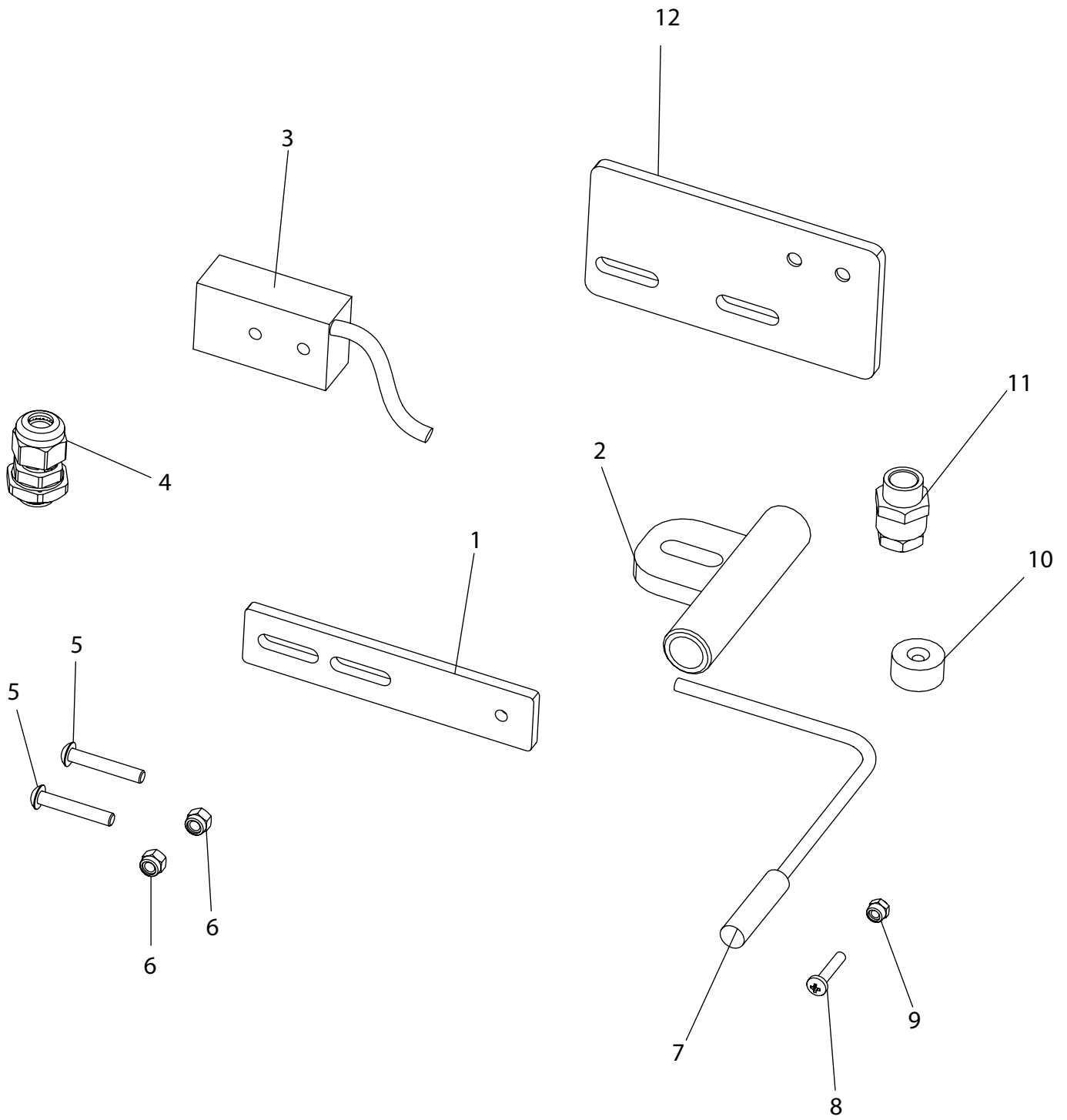

Item no.	Part no.	Qty	Description	Comments
1	1009347	1	Bracket for sensor magnet	
2	1008265	1	Pipe for end stop sensor	
3	1007561	1	Dual sensor	
4	1005535-1	1	Cable coupling Rear axle assembly	
5	763782	2	M5 x 30 Int. hex	
6	044005	1	M5 Lock nut	
7	1007560	1	Sensor	
8	034604020	1	M4 x 20 Machine screw	
9	044004	1	M4 Lock nut	
10	1005530	1	Magnet	
11	1005535	1	Cable coupling Sensor	
12	1009255	1	Bracket for coupling housing sensor	

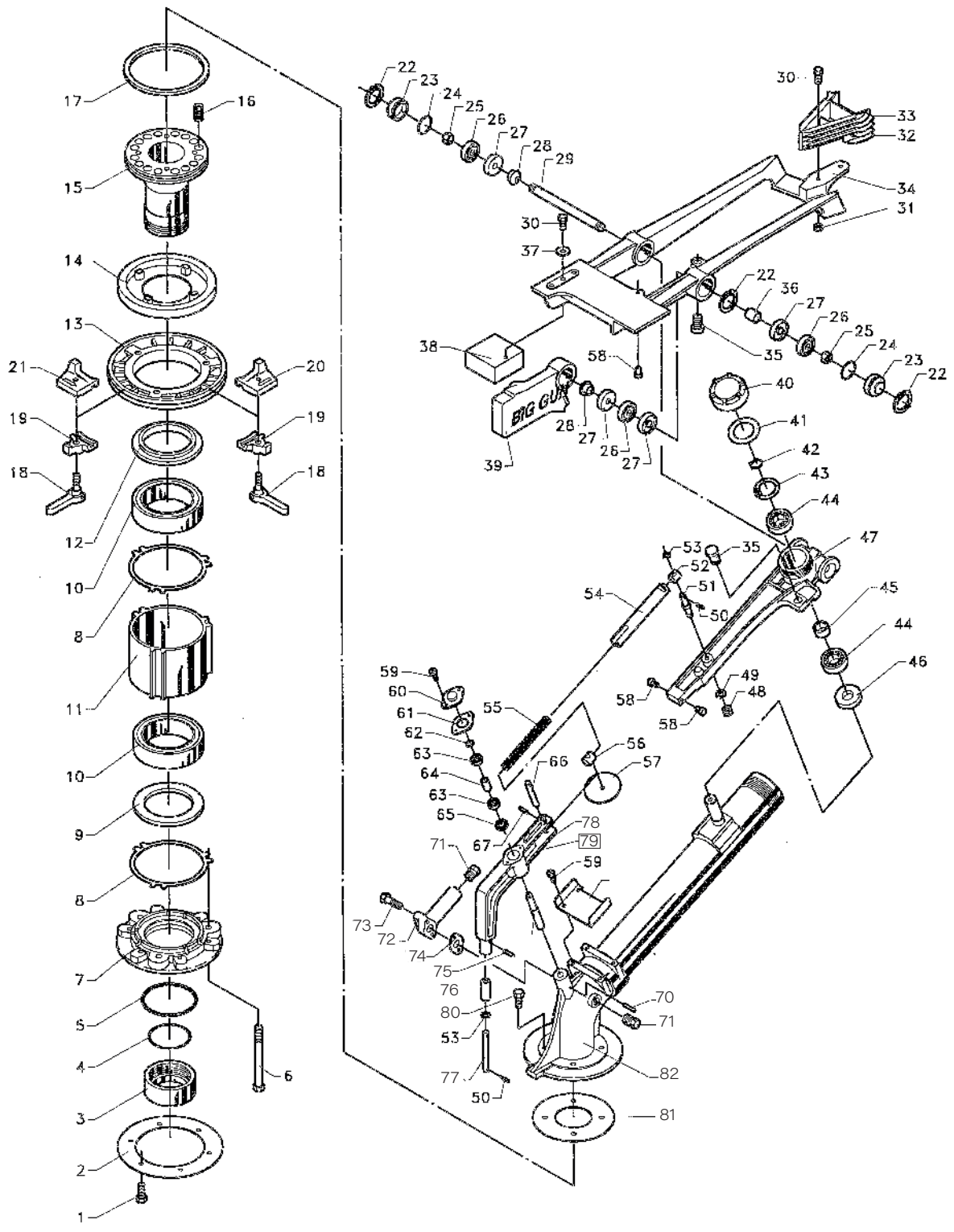

Item no.	Part no.	Qty	Description	Comments
1	776849	1	Bolt	
2	761614	1	Flange gasket for gun	
3	778402	1	Lock nut	
4	776548	1	O-ring	
5	778475	1	O-ring	
6	778462	3	Bolt	
7	778401	1	Base piece	
8	778461	2	Gasket	
9	778373	1	Sealing ring	
10	776253	2	Ball bearing	
11	778405	1	Bearing housing	
12	778372	1	Sealing ring	
13	778400	1	Brake disc	
14	778371	1	Brake lining	
15	778459	1	Bearing pipe	
16	778474	12	Spring	
17	778473	1	Sealing ring	
18	776849	2	Bolt	
19	776371	2	Bracket	
20	778432	1	Wheel chock Left	
21	778431	1	Wheel chock Right	
22	776565	3	Retaining ring	
23	776602	2	End cover	
24	776563	2	O-ring	
25	776603	2	Nut	
26	776598	3	Ball bearing	
27	776600	4	Sealing ring	
28	776607	2	Spacer pipe	
29	778465	1	Shaft	
30	776818	2	Bolt	
31	776060	2	Nut	
32	778354	1	Drive blade	
33	779229	1	Drive blade Topspeed	
34	778364	1	Drive arm	
35	778139	2	Rubber stop	
36	778327	1	Spacer pipe	
37	776070	1	Flat washer	
38	778433	1	Weight block	
39	778366	1	Counterweight	
40	778233	1	Cover	
41	778272	1	Gasket	

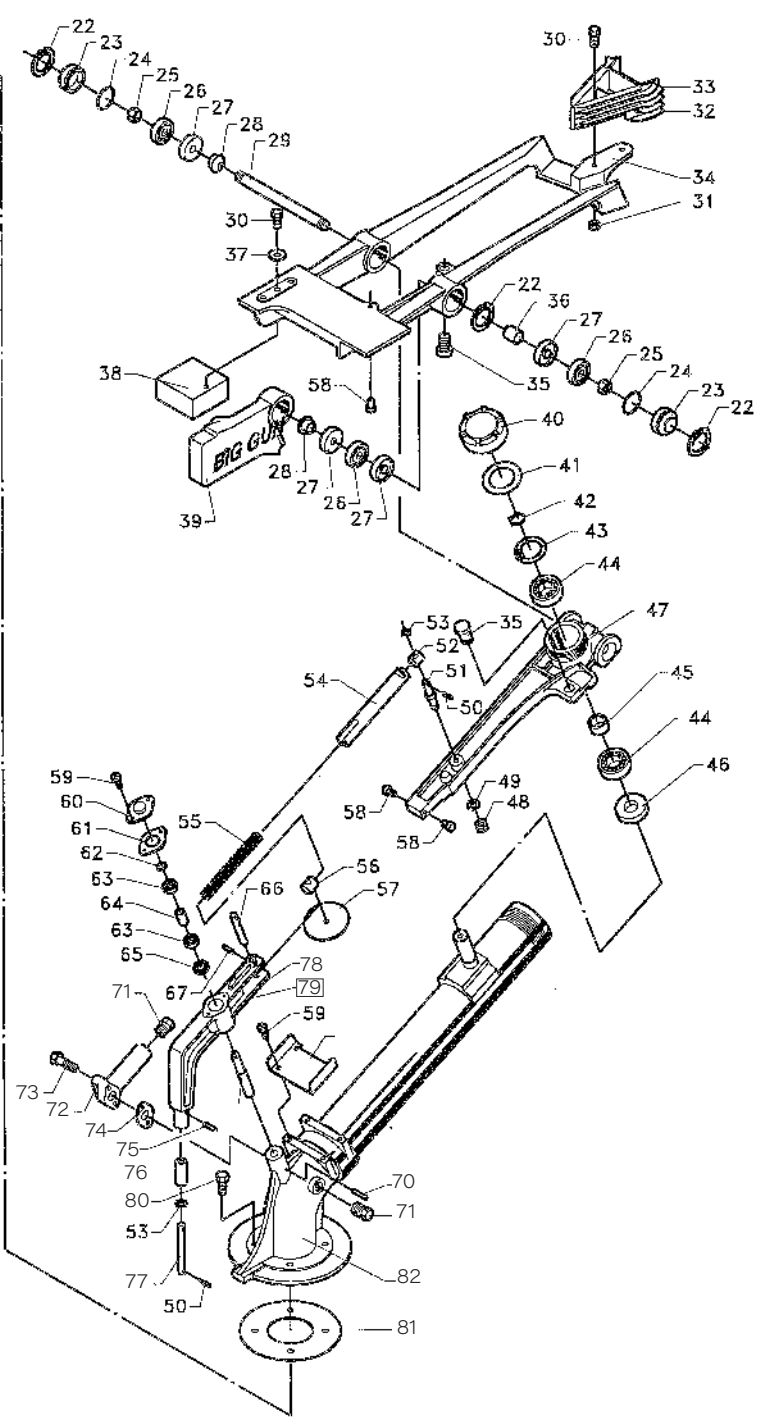
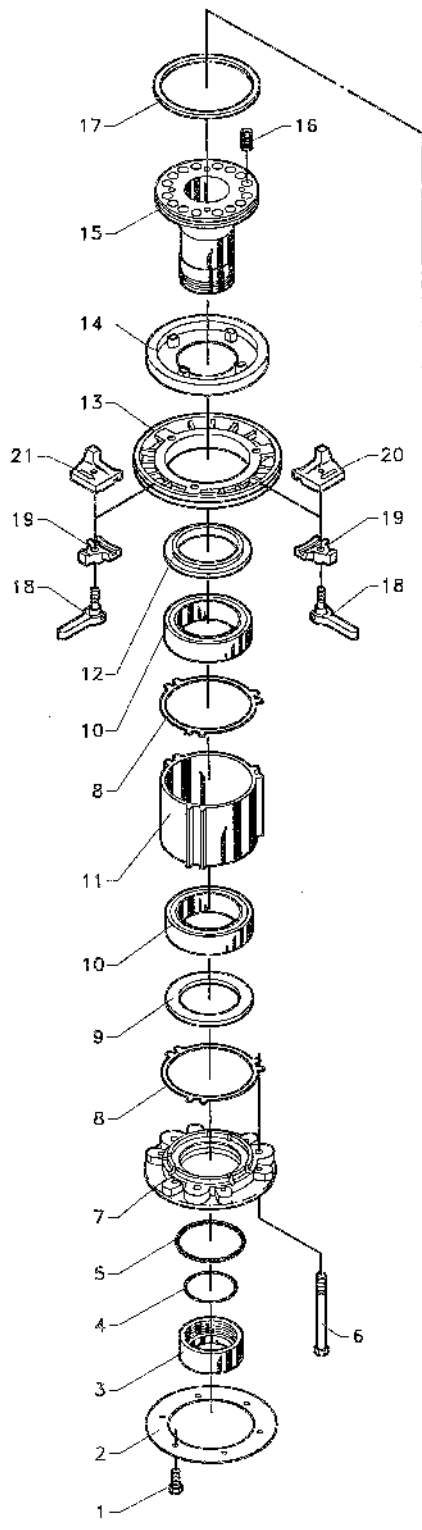

Item no.	Part no.	Qty	Description	Comments
42	778323-017	1	Retaining ring	
43	776045	1	Retaining ring	
44	776054	2	Ball bearing	
45	778326	1	Spacer pipe	
46	776048	1	Oil seal ring	
47	778394	1	Switch lever	
48	776064	1	Nut	
49	777029	1	Washer	
50	776714	2	Split pin	
51	778197	1	Bolt	
52	778282	1	Shaft	
53	778409	2	Flat washer	
54	778446	1	Pipe	
55	778470	1	Spring	
56	778417	1	Shaft	
57	778336	1	Washer	
58	776580	3	Stop pin	
59	778311	2	Screw	
60	778263	1	Cover	
61	778265	1	Gasket	
62	778323-004	1	Retaining ring	
63	778321	2	Bearing	
64	778281	1	Spacer pipe	
65	778317	1	Seal	
66	778193	1	Pin	
67	778320	1	Split pin	
68	778448	1	Plate	
69	778274	1	Shaft	
70	776931	1	Locking pin	
71	776089	2	Plug	
72	778497	1	Nozzle pipe	
73	776059	2	Bolt	
74	778511	1	Gasket	
75	778322	1	Split pin	
76	778277	1	Roller	
77	778276	1	Shaft	
78	778410	1	Arm trip lever	
79	778451	1	Complete switch	
80	778408	4	Bolt	
81	778460	1	Gasket	
82	778587	1	Jet pipe	

Optional equipment

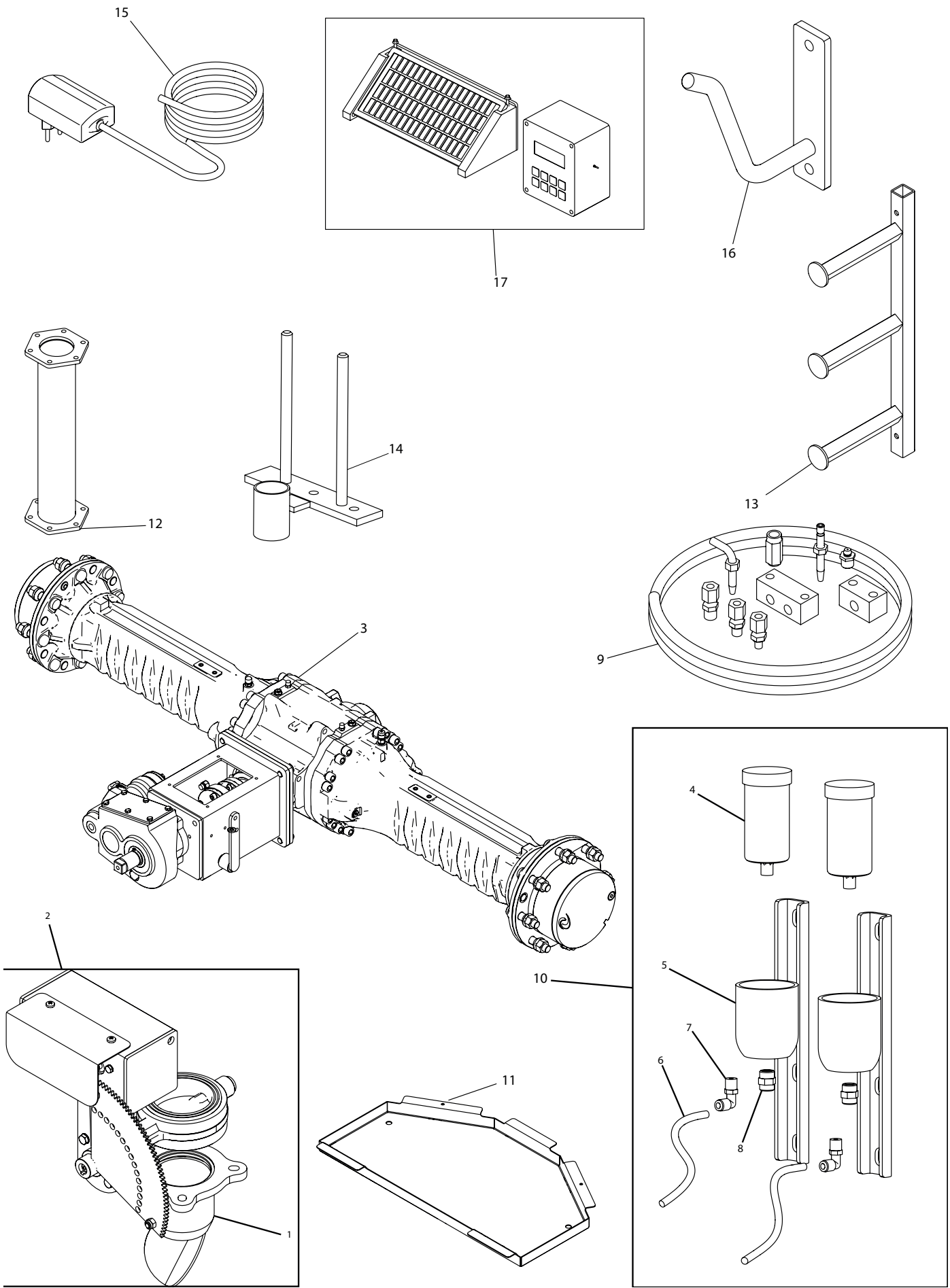

Item no.	Part no.	Qty	Description	Comments
1	2010507	1	Stop for negative pressure	
2	2010508	1	Over/negative pressure set	
3	2010505	1	Rear axle assembly Track width 2000	
4	7550LAGD125/WA2	2	Grease cup system	
5	1008490-1	2	Brace for support pipe carriage	
6	1013860	2	Air hose	
7	591197	2	Swivel angle	
8	1916650202B	2	Sleeve	
9	2010525	1	Central lubrication main bearings	
10	2010534	1	Central lubrication for hose guide	
11	2001754	1	Base plate for tool box	
12	762006	1	Extension pipe for gun	
13	1010530	1	Ladder	
14	2002928	1	Holder for nozzle and nozzle key	
15	1005522	1	Charging unit for 12 V	
16	762077	1	Suspension hook for charge hose	
17	2010530	1	Teleregn/GSM module	

1

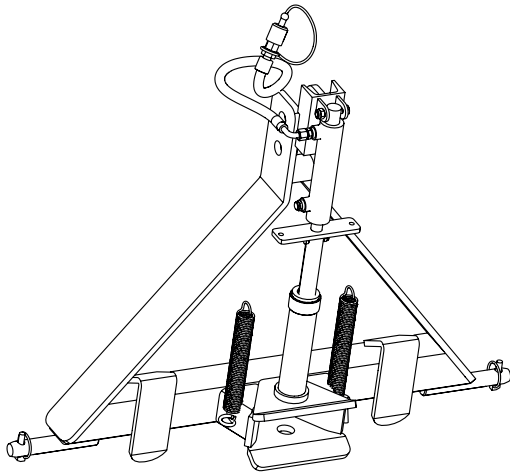

2

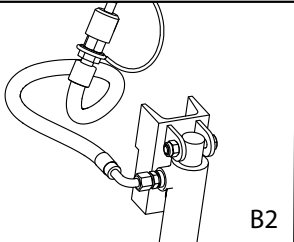
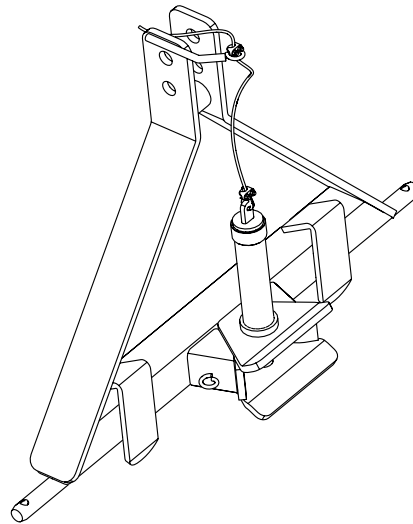

B2

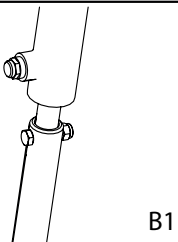

B1

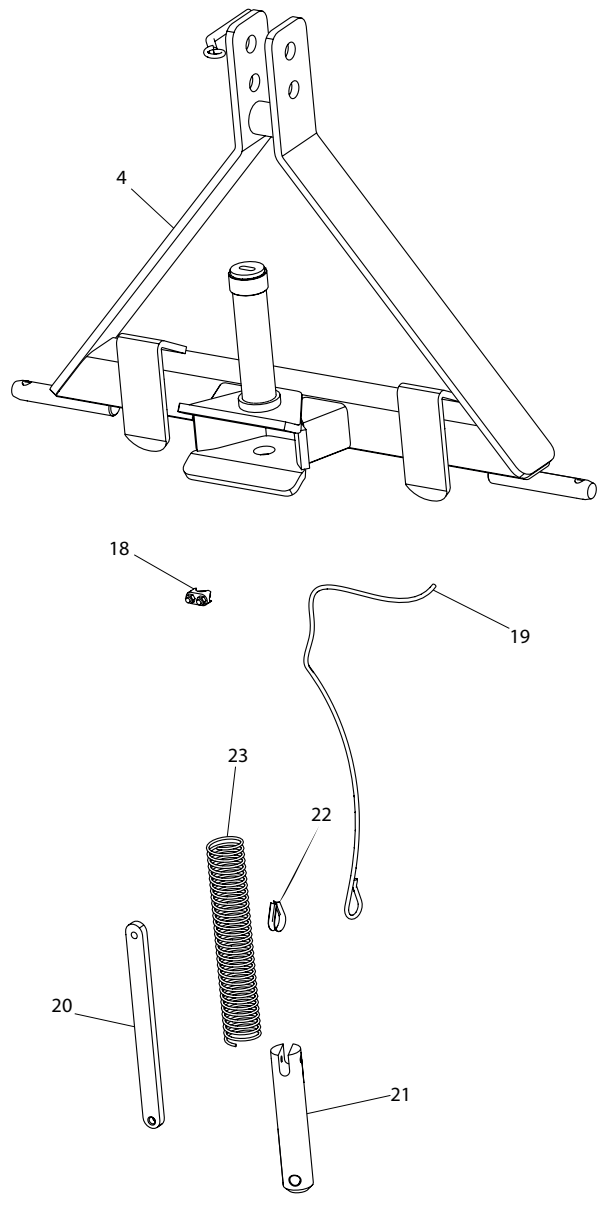
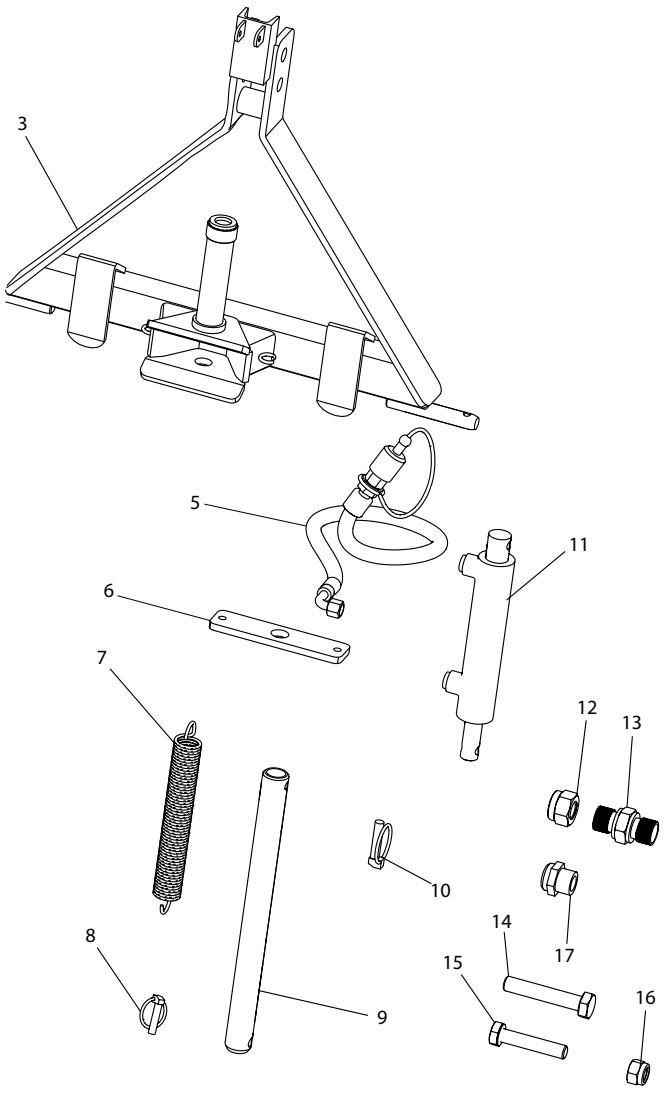

Item no.	Part no.	Qty	Description	Comments
1	1008280-1	1	A-frame Hydraulics	
2	1008280	1	A-frame Cable	
3	1008281-2	1	A-frame for hydraulics	
4	1008281	1	A-frame	
5	1008288	1	Hydraulic hose	
6	1008285	1	Hole plate for hydraulics	
7	761274	2	Spring	
8	1302100800	1	Securing pin 8x45	
9	1008283	1	Drawbar pin A-frame hydraulic	
10	1302101000	5	Securing pin 10x45	
11	1008287	1	Cylinder for A-frame	
12	044010	1	M10 Lock nut	B2
13	121001BP04	1	Nipple	
14	021010055	1	M10x55 Steel bolt 8.8	B2
15	021008040	1	M8x40 Steel bolt 8.8	B1
16	044008	1	M8 Lock nut	B1
17	591575	1	Filter plug, Silencer	
18	1562220206	3	Cable lock	
19	1008292	1	Cable with nylon for A-frame	
20	1008284	1	Arm for Drawbar pin	
21	1008282	1	Drawbar pin for A-frame	
22	761012-1	1	Cable thimbles	
23	1008290	1	Compression spring for A-frame	

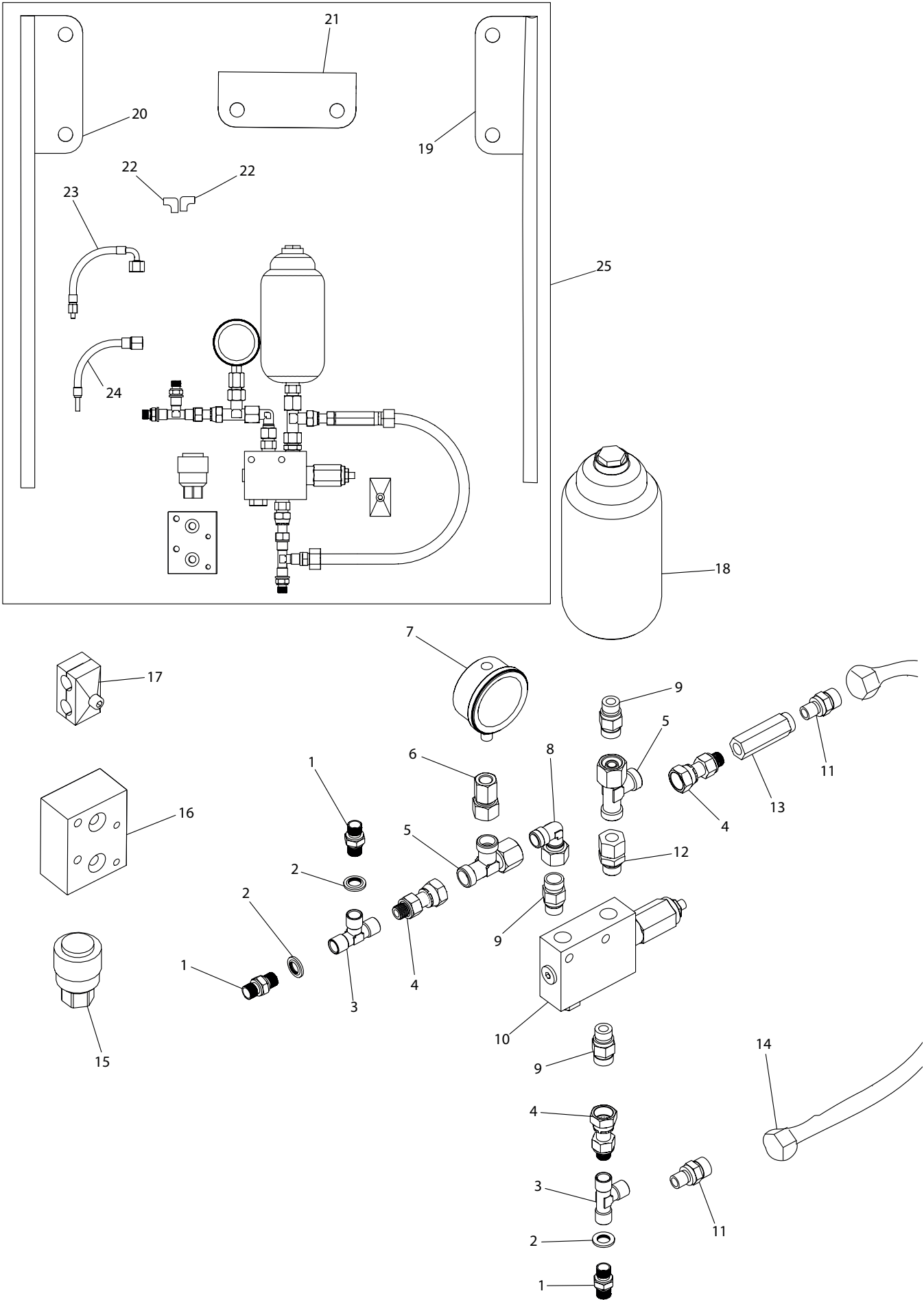

Item no.	Part no.	Qty	Description	Comments
1	121001BP04	3	Nipple	
2	552026	3	Sealing ring 1/4	
3	1013814	2	Tee 1/4 x 1/4 x 1/4 int.	
4	1010976	3	Nipple straight 1/4	
5	1007531	2	Tee Ø12 fixed bypass x Ø12 x Ø12	
6	1010979	1	Nipple straight for manometer	
7	761163-4	1	Manometer	
8	1220SV12L	1	Adjustable angle Ø12	
9	1007724	3	Nipple straight 3/8	
10	1013835	1	Brake valve	
11	1010978	2	Nipple straight 1/4 x Ø12	
12	890414	1	Nipple straight 3/8 x 12 bypass Fixed bypass	
13	1210C055CA07	1	Check valve	
14	1008610	1	Hose 3/8 X 400 mm	
15	1013817	1	Brake Hyd. Coupling 1/2 int. thread	
16	2004448	1	Assembly block	
17	1007514	10	Hose carrier	
18	1013837	1	Accumulator for brake	
19	2008065	1	Reinforcement for rear end Right	
20	2008066	1	Reinforcement for rear end Left	
21	2008064-1	2	Clamping bracket for reinforcement	
22	1013845	2	Angle screw fitting	
23	1013843	1	Brake hose 3/16 x 500 mm	
24	1013842	1	Brake hose 3/16 x 650 mm	
25	2010601	1	Hydraulic brake set	

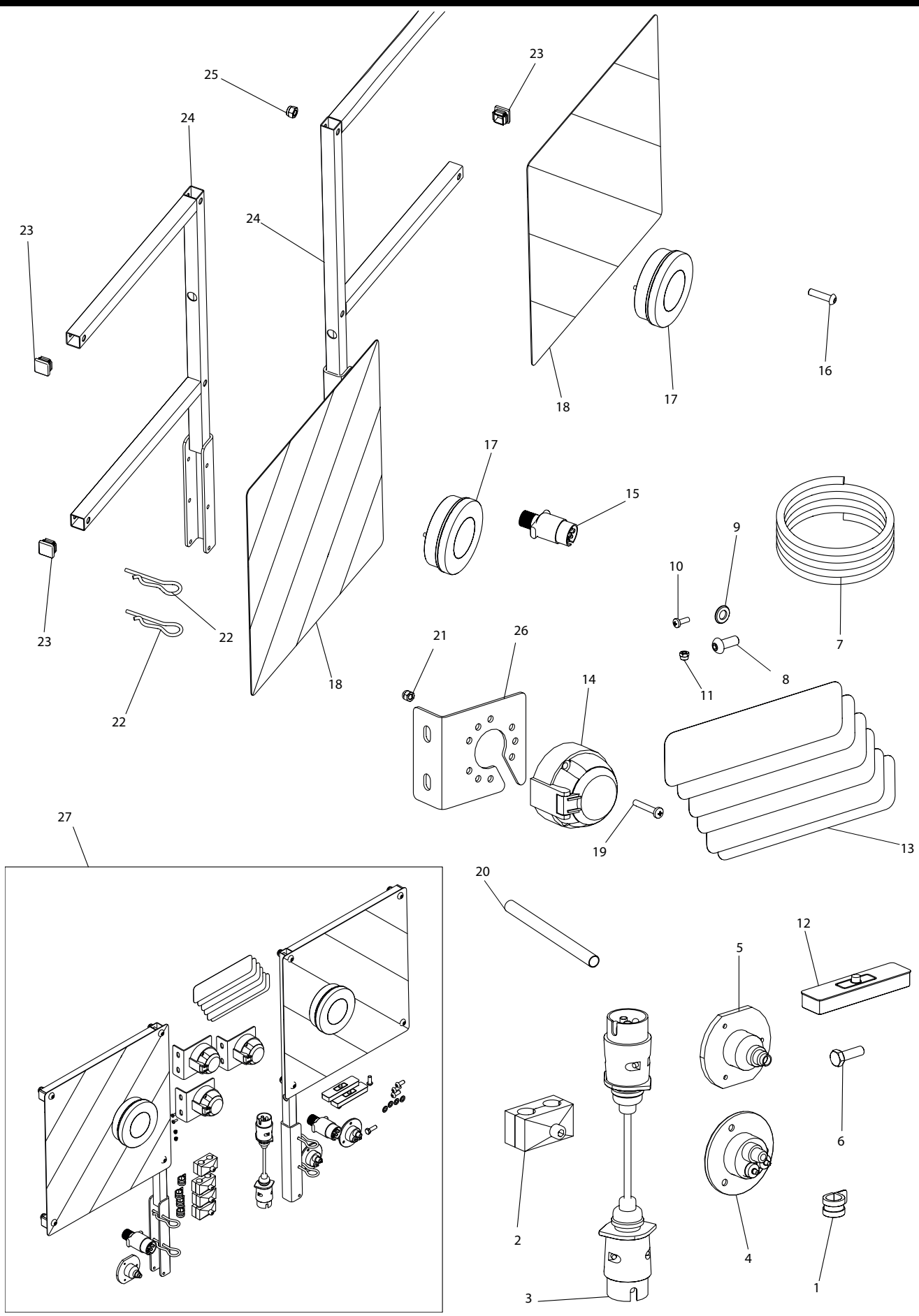

Item no.	Part no.	Qty	Description	Comments
1	1150700018	4	ABA Rubber clamp	
2	1007514	4	Hose carrier	
3	S1120	1	5.5m cable incl. male connector	
4	1008961	2	Rubber backing for socket	
5	1008962	1	Rubber backing for socket	
6	022208025	2	M8x25 Set bolt	
7	1013505	11.25 m	Plastic cable	
8	095008020	4	M8x20 Round head int. hex	
9	050208	4	M8 Plain washer	
10	034404012	4	M4x12 Machine screw	
11	044004	4	M4 Lock nut	
12	1013502	2	Item Light LED	
13	1415003005	6	Reflector	
14	1008960	3	Female connector for electric brake	
15	1008965	2	Male connector for electric brake	
16	095010040	8	M10x40 Int. hex Round head	
17	1013510	2	Rear light LED	
18	1013503	4	Warning sign	
19	034405030	9	M5x30 Machine screw	
20	026150223	2.3 m	Ø18x1.2 Galvanized pipe	
21	044005	9	M5 Lock nut	
22	1303100050	4	Retaining pin	
23	684125	4	25 mm Pipe end cap	
24	2004100	2	Holder for side markers	
25	044008	2	M8 Lock nut	
26	1013873	3	Suspension bracket	
27	2010610	1	Light set	

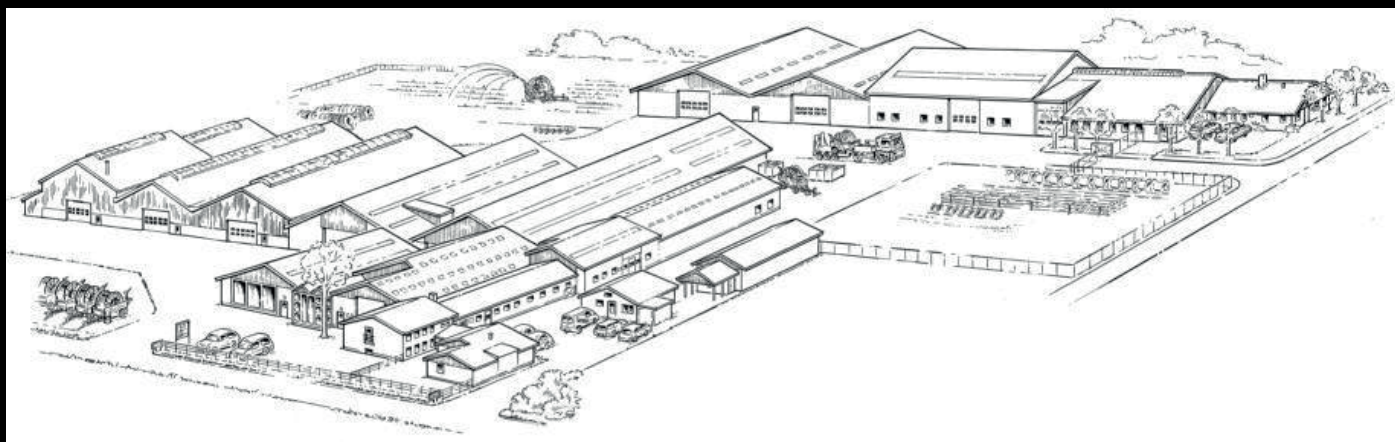

FASTERHOLT

**A/S FASTERHOLT MASKINFABRIK
EJSTRUPVEJ 22, DK-7330 BRANDE
DANMARK**

TEL.: +45 97 18 80 66 FAX: +45 97 18 80 40

E-MAIL: MAIL@FASTERHOLT.DK

www.fasterholt.dk